



CADET
INFORMATION
MANUAL

**CADET
INFORMATION
MANUAL**

**CADET
PA-28-161**

HANDBOOK PART NO. 761 826

PIPER AIRCRAFT CORPORATION
PA-28-101, CADET

Published by
PUBLICATIONS DEPARTMENT
Piper Aircraft Corporation
Issued: September 9, 1988

REPORT: VB-1360
ii

ISSUED: SEPTEMBER 9, 1988

APPLICABILITY

Application of this handbook is limited to the specific Piper PA-28-161 model airplane designated by serial number and registration number on the face of the title page of this handbook.

This handbook cannot be used for operational purposes unless kept in a current status.

REVISIONS

The information compiled in the Pilot's Operating Handbook, with the exception of the equipment list, will be kept current by revisions distributed to the airplane owners. The equipment list was current at the time the airplane was licensed by the manufacturer and thereafter must be maintained by the owner.

Revision material will consist of information necessary to update the text of the present handbook and/or to add information to cover added airplane equipment.

I. Revisions

Revisions will be distributed whenever necessary as complete page replacements or additions and shall be inserted into the handbook in accordance with the instructions given below:

1. Revision pages will replace only pages with the same page number.
2. Insert all additional pages in proper numerical order within each section.
3. Page numbers followed by a small letter shall be inserted in direct sequence with the same common numbered page.

II. Identification of Revised Material

Revised text and illustrations shall be indicated by a black vertical line along the outside margin of the page, opposite revised, added or deleted material. A line along the outside margin of the page opposite the page number will indicate that an entire page has been changed or added.

PIPER AIRCRAFT CORPORATION
PA-28-161, CADET

Black lines will indicate only current revisions with changes and additions to or deletions of existing text and illustrations. Changes in capitalization, spelling, punctuation or the physical location of material on a page will not be identified by symbols.

ORIGINAL PAGES ISSUED

The original pages issued for this handbook prior to revision are given below:

Title, ii through vii, 1-1 through 1-18, 2-1 through 2-10, 3-1 through 3-16, 4-1 through 4-30, 5-1 through 5-28, 6-1 through 6-14, 7-1 through 7-26, 8-1 through 8-18, 9-1 through 9-36 and 10-1 through 10-2.

PIPER AIRCRAFT CORPORATION
PA-28-161, CADET

PILOT'S OPERATING HANDBOOK LOG OF REVISIONS

Current Revisions to the PA-28-161, Cadet Pilot's Operating Handbook,
 REPORT: VB-1360 issued September 9, 1988

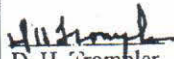
Revision Number and Code	Revised Pages	Description of Revisions	FAA Approval Signature and Date
Rev. 1 (PR881216)	v	Added Rev. 1	
	2-11	Page added. Placard added.	
	2-12	Page added.	
	4-4	Revised para. 4.5b.	
	4-8	Revised para. 4.5f.	
	4-9	Revised para. 4.5h.	
	4-10	Revised para's. 4.5h and 4.5i.	
	4-13	Revised para. 4.5o.	
	4-15	Revised para. 4.11a.	
	4-22	Revised para. 4.23.	
	4-23	Revised para. 4.25a.	
	4-27	Revised para. 4.35.	
	5-9	Revised List of Figures.	
	5-13a	Page added.	
	5-13b	Added page and fig. 5-6	
	5-23	Graph added.	
	5-24	Graph added.	
5-25	Graph added.		
5-27	Graph added.		
			 D. H. Trompler <u>Jan 9, 1989</u> Date
Rev. 2 (PR890315)	v	Added Rev 2	
	2-5	Revised para. 2.19.	
	2-6	Revised para. 2.19, item 7.	
			 D. H. Trompler <u>March 17, 1989</u> Date
Rev. 3 (PR890404)	v,	Added Rev 3	
	vi		
	2-11	Placard added.	
	5-3	Revised para. 5.5, (a), (7).	
5-6	Revised para. 5.5, (e), (2).		

ISSUED: SEPTEMBER 9, 1988
 REVISED: SEPTEMBER 12, 1990

REPORT: VB-1360

PIPER AIRCRAFT CORPORATION
PA-28-161, CADET

PILOT'S OPERATING HANDBOOK LOG OF REVISIONS (cont)

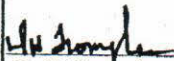
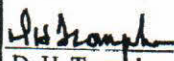
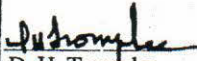
Revision Number and Code	Revised Pages	Description of Revisions	FAA Approval Signature and Date
	5-7 5-15 5-16 5-17 5-22 6-7 7-7 7-13 8-7 9-27	Revised para's. 5.5, (f), (1) and (g), (1). Revised figure 5-9. Revised figure 5-11. Revised figure 5-13. Revised figure 5-23. Revised figure 6-5. Revised figure 7-5. Revised para. 7.17. Revised para. 8.9, (d), (7). Revised figure 7-9, item 4.	 D. H. Trompler May 19, 1989 Date
Rev. 4 (PR891016)	v vi 7-24a, 7-24b	Added page 5-23 to Rev 1 Log of Revisions. Added Revision 4. Pages added. Narco ELT 910 added.	 D. H. Trompler October 17, 1989 Date
Rev. 5 (PR891127)	vi 5-15 thru 5-17 5-22 5-25 6-i 6-14 6-15 thru 6-18 7-7 7-13	Added Revision 5. Correct footers. Revised figure 5-23. Correct footer. Revised figure 5-29. Revised T.O.C.. Add para 6.9. Add pages. Para. 6.9 continued. Correct footer. Correct footer.	 D. H. Trompler Jan 18, 1990 Date

**PIPER AIRCRAFT CORPORATION
PA-28-161, CADET**

PILOT'S OPERATING HANDBOOK LOG OF REVISIONS (cont)

Revision Number and Code	Revised Pages	Description of Revisions	FAA Approval Signature and Date
Rev. 6 (PR900912)	v	Editorial corrections.	
	vi	Editorial corrections.	
	vi-a	Added page & Revision 6.	
	1-3	Revised para. 1.5	
	1-4	Revised para. 1.9.	
	1-5, 1-7	Corrected para. 1.19 title.	
	thru		
	1-10		
	2-3	Revised para's. 2.7 (j) and (l).	
		Added para. 2.7 (m) and Notes.	
		Moved info to page 2-3a.	
	2-3a	Page added. Relocated info.	
	2-3b	from page 2-3.	
	2-5	Page added.	
2-5	Revised para. 2.15.		
6-10	Revised figure 6-9.		
7-2	Revised para. 7.5.		
8-3	Revised para. 8.5.		
8-11	Revised para's. 8.19 & 8.21.		
8-12	Revised para. 8.21.		

D. H. Trompler
D. H. Trompler
Oct. 5, 1990
Date

ISSUED: SEPTEMBER 12, 1990

REPORT: VB-1360
vi-a

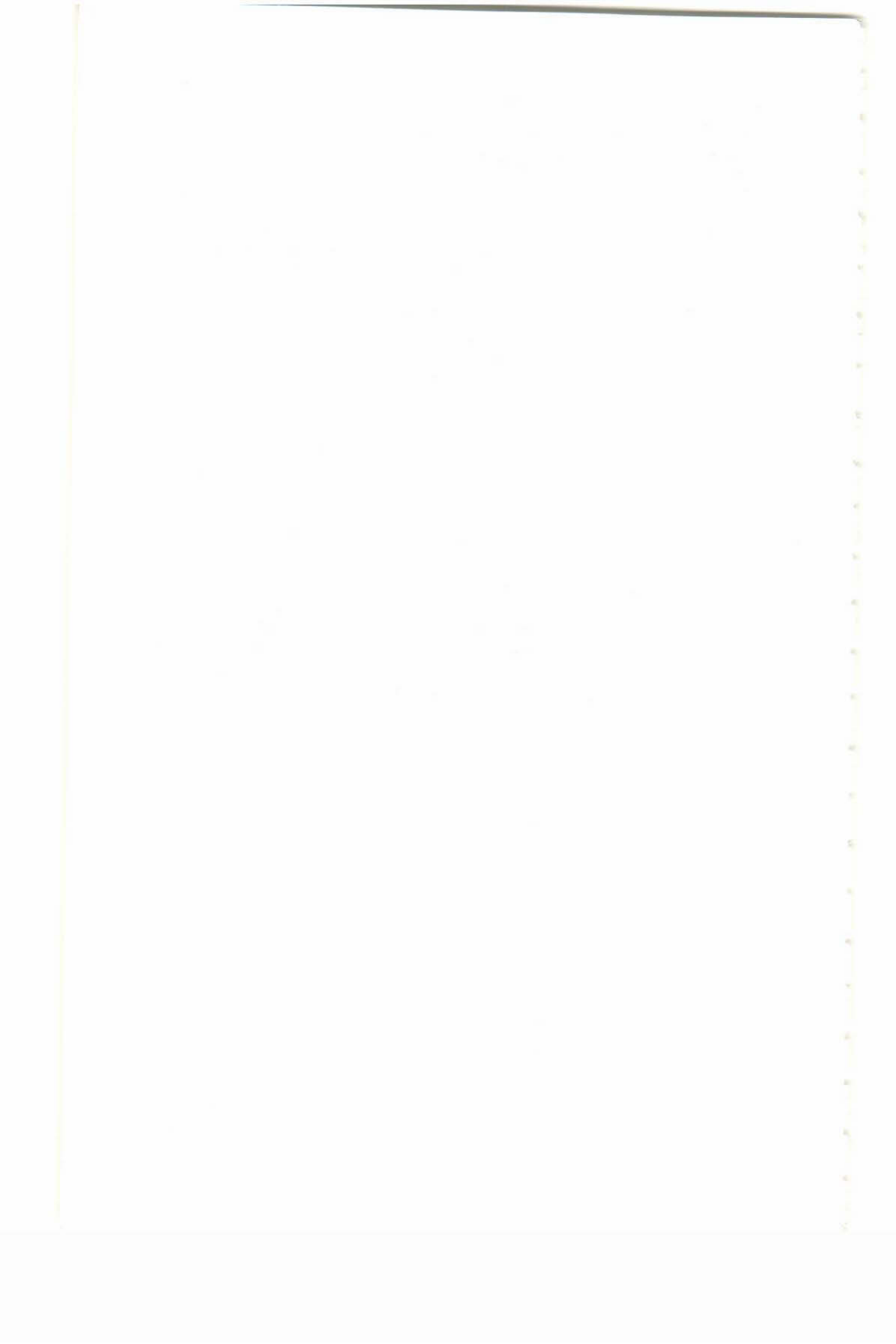

TABLE OF CONTENTS

SECTION 1	GENERAL
SECTION 2	LIMITATIONS
SECTION 3	EMERGENCY PROCEDURES
SECTION 4	NORMAL PROCEDURES
SECTION 5	PERFORMANCE
SECTION 6	WEIGHT AND BALANCE
SECTION 7	DESCRIPTION AND OPERATION OF THE AIRPLANE AND ITS SYSTEMS
SECTION 8	AIRPLANE HANDLING, SERVICING AND MAINTENANCE
SECTION 9	SUPPLEMENTS
SECTION 10	OPERATING TIPS



**TABLE OF CONTENTS
SECTION I
GENERAL**

Paragraph No.		Page No.
1.1	Introduction	1-1
1.3	Engines	1-3
1.5	Propellers	1-3
1.7	Fuel	1-3
1.9	Oil.....	1-4
1.11	Maximum Weights	1-4
1.13	Standard Airplane Weight	1-4
1.15	Baggage Space	1-4
1.17	Specific Loadings	1-4
1.19	Symbols, Abbreviations and Terminology.....	1-5

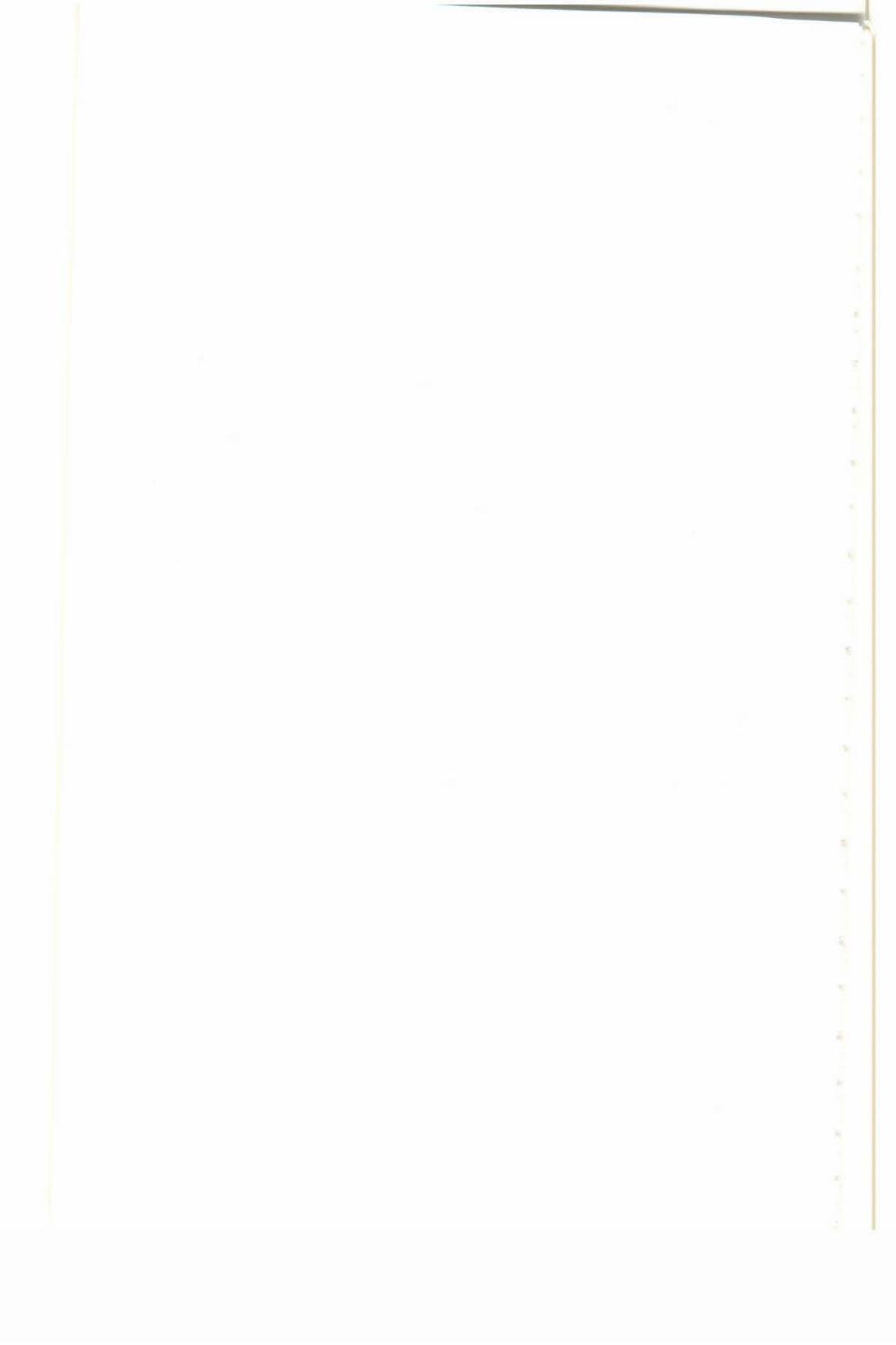

**SECTION 1
GENERAL**

1.1 INTRODUCTION

This Pilot's Operating Handbook is designed for maximum utilization as an operating guide for the pilot. It includes the material required to be furnished to the pilot by the Federal Aviation Regulations and additional information provided by the manufacturer and constitutes the FAA Approved Airplane Flight Manual.

This handbook is not designed as a substitute for adequate and competent flight instruction, knowledge of current airworthiness directives, applicable federal air regulations or advisory circulars. It is not intended to be a guide for basic flight instruction or a training manual and should not be used for operational purposes unless kept in a current status.

Assurance that the airplane is in an airworthy condition is the responsibility of the owner. The pilot in command is responsible for determining that the airplane is safe for flight. The pilot is also responsible for remaining within the operating limitations as outlined by instrument markings, placards, and this handbook.

Although the arrangement of this handbook is intended to increase its in-flight capabilities, it should not be used solely as an occasional operating reference. The pilot should study the entire handbook to familiarize himself with the limitations, performance, procedures and operational handling characteristics of the airplane before flight.

The handbook has been divided into numbered (arabic) sections, each provided with a finger-tip tab divider for quick reference. The limitations and emergency procedures have been placed ahead of the normal procedures, performance and other sections to provide easier access to information that may be required in flight. The Emergency Procedures Section has been furnished with a red tab divider to present an instant reference to the section. Provisions for expansion of the handbook have been made by the deliberate omission of certain paragraph numbers, figure numbers, item numbers and pages noted as being intentionally left blank.

SECTION 1
GENERAL

PIPER AIRCRAFT CORPORATION
PA-28-161, CADET

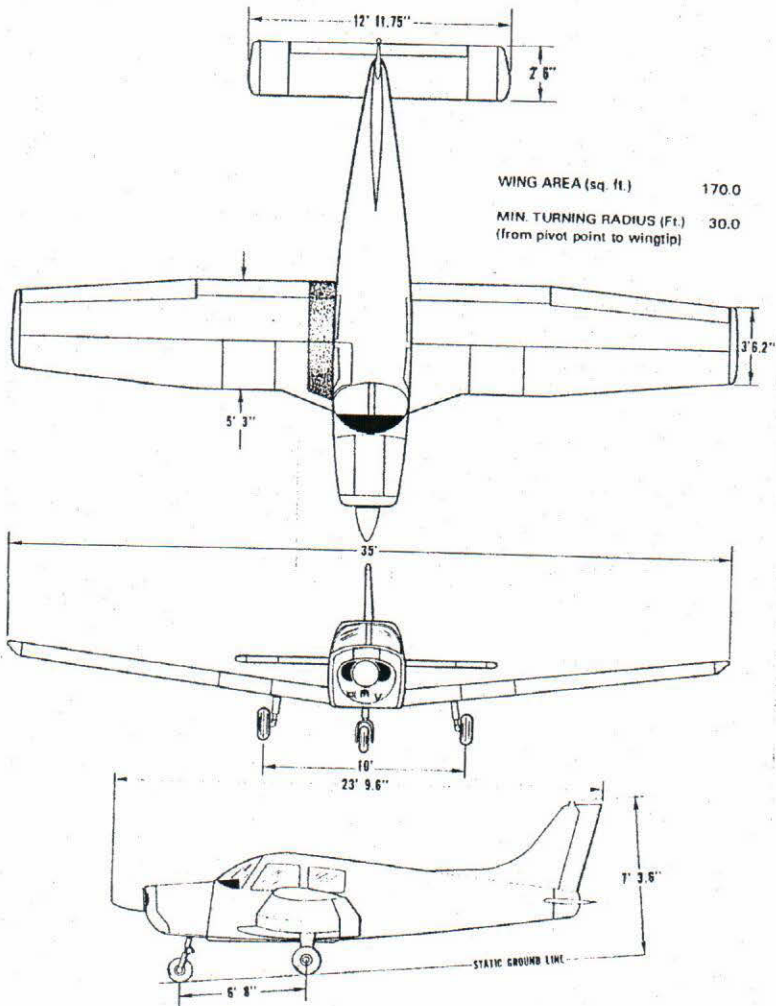

THREE VIEW
Figure 1-1

1.3 ENGINES

(a) Number of Engines	1
(b) Engine Manufacturer	Lycoming
(c) Engine Model Number	O-320-D2A or O-320-D3G
(d) Rated Horsepower	160
(e) Rated Speed (rpm)	2700
(f) Bore (inches)	5.125
(g) Stroke (inches)	3.875
(h) Displacement (cubic inches)	319.8
(i) Compression Ratio	8.5:1
(j) Engine Type	Four Cylinder, Direct Drive, Horizontally Opposed, Air Cooled

1.5 PROPELLERS

(a) Number of Propellers	1
(b) Propeller Manufacturer	Sensenich
(c) Model	74DM6-0-60 or 74DM6-0-58
(d) Number of Blades	2
(e) Propeller Diameter (inches)	
(1) Maximum	74
(2) Minimum	72
(f) Propeller Type	Fixed Pitch

1.7 FUEL

AVGAS ONLY

(a) Fuel Capacity (U.S. gal) (total)	50
(b) Usable Fuel (U.S. gal) (total)	48
(c) Fuel	
(1) Minimum Octane	100 Green or 100LL Blue Aviation Grade
(2) Alternate Fuel	Refer to Fuel Requirements, Section 8 - Handling, Servicing and Maintenance.

**SECTION 1
GENERAL**

**PIPER AIRCRAFT CORPORATION
PA-28-161, CADET**

1.9 OIL

- | | |
|--------------------------------|---|
| (a) Oil Capacity (U.S. quarts) | 8 |
| (b) Oil Specification | Refer to latest issue
of Lycoming Service
Instruction 1014. |
| (c) Oil Viscosity | Refer to Section 8 -
paragraph 8.19. |

1.11 MAXIMUM WEIGHTS

	Normal	Utility
(a) Maximum Ramp Weight (lbs)	2332	2027
(b) Maximum Takeoff Weight (lbs)	2325	2020
(c) Maximum Landing Weight (lbs)	2325	2020
(d) Maximum Weight in Baggage Compartment (lbs)	50	0

1.13 STANDARD AIRPLANE WEIGHTS

Refer to Figure 6-5 for the Standard Empty Weight and the Useful Load.

1.15 BAGGAGE SPACE

Compartment Volume (cubic feet)	24
---------------------------------	----

1.17 SPECIFIC LOADINGS

(a) Wing Loading (lbs per sq ft)	13.7
(b) Power Loading (lbs per hp)	14.5

1.19 SYMBOLS, ABBREVIATIONS AND TERMINOLOGY

The following definitions are of symbols, abbreviations and terminology used throughout the handbook and those which may be of added operational significance to the pilot.

(a) General Airspeed Terminology and Symbols

CAS	Calibrated Airspeed means the indicated speed of an aircraft, corrected for position and instrument error. Calibrated airspeed is equal to true airspeed in standard atmosphere at sea level.
KCAS	Calibrated Airspeed expressed in Knots.
GS	Ground Speed is the speed of an airplane relative to the ground.
IAS	Indicated Airspeed is the speed of an aircraft as shown on the airspeed indicator when corrected for instrument error. IAS values published in this handbook assume zero instrument error.
KIAS	Indicated Airspeed expressed in Knots.
M	Mach Number is the ratio of true airspeed to the speed of sound.
TAS	True Airspeed is the airspeed of an airplane relative to undisturbed air which is the CAS corrected for altitude, temperature and compressibility.
V _A	Maneuvering Speed is the maximum speed at which application of full available aerodynamic control will not overstress the airplane.
V _{FE}	Maximum Flap Extended Speed is the highest speed permissible with wing flaps in a prescribed extended position.

1.19 SYMBOLS, ABBREVIATIONS AND TERMINOLOGY (Continued)

V _{NE} /M _{NE}	Never Exceed Speed or Mach Number is the speed limit that should not be exceeded at any time.
V _{NO}	Maximum Structural Cruising Speed is the speed that should not be exceeded except in smooth air and then only with caution.
V _s	Stalling Speed or the minimum steady flight speed at which the airplane is controllable.
V _{SO}	Stalling Speed or the minimum steady flight speed at which the airplane is controllable in the landing configuration.
V _X	Best Angle-of-Climb Speed is the airspeed which delivers the greatest gain of altitude in the shortest possible horizontal distance.
V _Y	Best Rate-of-Climb Speed is the airspeed which delivers the greatest gain in altitude in the shortest possible time.

(b) Meteorological Terminology

ISA	International Standard Atmosphere in which: The air is a dry perfect gas; The temperature at sea level is 15° Celsius (59° Fahrenheit); The pressure at sea level is 29.92 inches Hg (1013.2 mb); The temperature gradient from sea level to the altitude at which the temperature is -56.5°C (-69.7°F) is -0.00198°C (-0.003564°F) per foot and zero above that altitude.
OAT	Outside Air Temperature is the free air static temperature obtained either from in-flight temperature indications or ground meteorological sources, adjusted for instrument error and compressibility effects.

1.19 SYMBOLS, ABBREVIATIONS AND TERMINOLOGY (Continued)

Indicated Pressure Altitude	The number actually read from an altimeter when the barometric subscale has been set to 29.92 inches of mercury (1013.2 millibars).
Pressure Altitude	Altitude measured from standard sea-level pressure (29.92 in. Hg) by a pressure or barometric altimeter. It is the indicated pressure altitude corrected for position and instrument error. In this handbook, altimeter instrument errors are assumed to be zero.
Station Pressure	Actual atmospheric pressure at field elevation.
Wind	The wind velocities recorded as variables on the charts of this handbook are to be understood as the headwind or tailwind components of the reported winds.

(c) Power Terminology

Takeoff Power	Maximum power permissible for takeoff.
Maximum Continuous Power	Maximum power permissible continuously during flight.
Maximum Climb Power	Maximum power permissible during climb.
Maximum Cruise Power	Maximum power permissible during cruise.

(d) Engine Instruments

EGT Gauge	Exhaust Gas Temperature Gauge
-----------	-------------------------------

[1.19 SYMBOLS, ABBREVIATIONS AND TERMINOLOGY (Continued)

(c) Airplane Performance and Flight Planning Terminology

Climb Gradient	The demonstrated ratio of the change in height during a portion of a climb, to the horizontal distance traversed in the same time interval.
Demonstrated Crosswind Velocity	The demonstrated crosswind velocity is the velocity of the crosswind component for which adequate control of the airplane during takeoff and landing was actually demonstrated during certification tests.
Accelerate-Stop Distance	The distance required to accelerate an airplane to a specified speed and, assuming failure of an engine at the instant that speed is attained, to bring the airplane to a stop.
Route Segment	A part of a route. Each end of that part is identified by (1) a geographical location or (2) a point at which a definite radio fix can be established.

(f) Weight and Balance Terminology

Reference Datum	An imaginary vertical plane from which all horizontal distances are measured for balance purposes.
Station	A location along the airplane fuselage usually given in terms of distance from the reference datum.
Arm	The horizontal distance from the reference datum to the center of gravity (C.G.) of an item.

1.19 SYMBOLS, ABBREVIATIONS AND TERMINOLOGY (Continued)

Moment	The product of the weight of an item multiplied by its arm. (Moment divided by a constant is used to simplify balance calculations by reducing the number of digits.)
Center of Gravity (C.G.)	The point at which an airplane would balance if suspended. Its distance from the reference datum is found by dividing the total moment by the total weight of the airplane.
C.G. Arm	The arm obtained by adding the airplane's individual moments and dividing the sum by the total weight.
C.G. Limits	The extreme center of gravity locations within which the airplane must be operated at a given weight.
Usable Fuel	Fuel available for flight planning.
Unusable Fuel	Fuel remaining after a runout test has been completed in accordance with governmental regulations.
Standard Empty Weight	Weight of a standard airplane including unusable fuel, full operating fluids and full oil.
Basic Empty Weight	Standard empty weight plus optional equipment.
Payload	Weight of occupants, cargo and baggage.
Useful Load	Difference between takeoff weight, or ramp weight if applicable, and basic empty weight.
Maximum Ramp Weight	Maximum weight approved for ground maneuver. (It includes weight of start, taxi and run up fuel.)

| 1.19 SYMBOLS, ABBREVIATIONS AND TERMINOLOGY (Continued)

Maximum Takeoff Weight	Maximum weight approved for the start of the takeoff run.
Maximum Landing Weight	Maximum weight approved for the landing touchdown.
Maximum Zero Fuel Weight	Maximum weight exclusive of usable fuel.

TABLE OF CONTENTS

SECTION 2

LIMITATIONS

Paragraph No.		Page No.
2.1	General	2-1
2.3	Airspeed Limitations.....	2-1
2.5	Airspeed Indicator Markings.....	2-2
2.7	Power Plant Limitations	2-2
2.9	Power Plant Instrument Markings.....	2-3
2.11	Weight Limits.....	2-4
2.13	Center of Gravity Limits	2-4
2.15	Maneuver Limits	2-5
2.17	Flight Load Factors	2-5
2.19	Kinds of Operation Equipment List.....	2-5
2.21	Fuel Limitations	2-7
2.23	Placards.....	2-8

SECTION 2
LIMITATIONS

2.1 GENERAL

This section provides the FAA Approved operating limitations, instrument markings, color coding and basic placards necessary for operation of the airplane and its systems.

This airplane must be operated as a normal or utility category airplane in compliance with the operating limitations stated in the form of placards and markings and those given in this section and handbook.

Limitations associated with those optional systems and equipment which require handbook supplements can be found in Section 9 (Supplements).

2.3 AIRSPEED LIMITATIONS

SPEED	KIAS	KCAS
Never Exceed Speed (VNE) - Do not exceed this speed in any operation.	160	153
Maximum Structural Cruising Speed (VNO) - Do not exceed this speed except in smooth air and then only with caution.	126	122
Maximum Flaps Extended Speed (VFE) - Do not exceed this speed with the flaps extended.	103	100

2.3 AIRSPEED LIMITATIONS (Continued)

SPEED	KIAS	KCAS
Design Maneuvering Speed (V_A) - Do not make full or abrupt control movements above this speed.		
At 2325 LBS. G.W.	111	108
At 1531 LBS. G.W.	88	89

CAUTION

Maneuvering speed decreases at lighter weight as the effects of aerodynamic forces become more pronounced. Linear interpolation may be used for intermediate gross weights. Maneuvering speed should not be exceeded while operating in rough air.

2.5 AIRSPEED INDICATOR MARKINGS

MARKING	IAS
Red Radial Line (Never Exceed)	160 KTS
Yellow Arc (Caution Range - Smooth Air Only)	126 KTS to 160 KTS
Green Arc (Normal Operating Range)	50 KTS to 126 KTS
White Arc (Flap Down)	44 KTS to 103 KTS

2.7 POWER PLANT LIMITATIONS

(a) Number of Engines	1
(b) Engine Manufacturer	Lycoming
(c) Engine Model No.	O-320-D2A or O-320-D3G
(d) Engine Operating Limits	
(1) Maximum Horsepower	160
(2) Maximum Rotation Speed (RPM)	2700
(3) Maximum Oil Temperature	245° F
(e) Oil Pressure	
Minimum (red line)	25 PSI
Maximum (red line)	100 PSI
(f) Fuel Pressure	
Minimum (red line)	.5 PSI
Maximum (red line)	8 PSI

2.7 POWER PLANT LIMITATIONS (Continued)

(g) Fuel (AVGAS ONLY) (minimum grade)	100 or 100LL Aviation Grade
(h) Number of Propellers	1
(i) Propeller Manufacturer	Sensenich
(j) Propeller Model	74DM6-0-60 or 74DM6-0-58
(k) Propeller Diameter (Inches)	
Minimum	72
Maximum	74
(l) 74DM6-0-60 Propeller Tolerance (static rpm at maximum permissible throttle setting, Sea Level, ISA)	Not above 2430 RPM Not below 2330 RPM

NOTE

Refer to the airplane maintenance manual for test procedure to determine approved static rpm under non standard conditions.

(m) 74DM6-0-58 Propeller Tolerance (static RPM at maximum permissible throttle setting, Sea Level, ISA)	Not above 2465 RPM Not below 2365 RPM
---	--

NOTE

Refer to the airplane maintenance manual for test procedure to determine approved static rpm under non standard conditions.

2.9 POWER PLANT INSTRUMENT MARKINGS

(a) Tachometer	
Green Arc (Normal Operating Range)	500 to 2700 RPM
Red Line (Maximum Continuous Power)	2700 RPM
(b) Oil Temperature	
Green Arc (Normal Operating Range)	75° to 245°F
Red Line (Maximum)	245°F

2.9 POWER PLANT INSTRUMENT MARKINGS (Continued)

(c) Oil Pressure	
Green Arc (Normal Operating Range)	60 to 90 PSI
Yellow Arc (Caution Range) (Idle)	25 to 60 PSI
Yellow Arc (Ground Warm-Up)	90 to 100 PSI
Red Line (Minimum)	25 PSI
Red Line (Maximum)	100 PSI
(d) Fuel Pressure	
Green Arc (Normal Operating Range)	.5 to 8 PSI
Red Line (Minimum)	.5 PSI
Red Line (Maximum)	8 PSI

THIS PAGE INTENTIONALLY LEFT BLANK

ISSUED: SEPTEMBER 12, 1990

**REPORT: VB-1360 |
2-3b |**

**SECTION 2
LIMITATIONS**

**PIPER AIRCRAFT CORPORATION
PA-28-161, CADET**

2.11 WEIGHT LIMITS

	Normal	Utility
(a) Maximum Ramp Weight	2332 LBS	2027 LBS
(b) Maximum Takeoff Weight	2325 LBS	2020 LBS
(c) Maximum Landing Weight	2325 LBS	2020 LBS
(d) Maximum Baggage	50 LBS	0 LBS

NOTE

Refer to Section 5 (Performance) for maximum weight as limited by performance.

2.13 CENTER OF GRAVITY LIMITS

(a) Normal Category

Weight Pounds	Forward Limit Inches Aft of Datum	Rearward Limit Inches Aft of Datum
2325	87.0	93.0
1950 (and less)	83.0	93.0

(b) Utility Category

Weight Pounds	Forward Limit Inches Aft of Datum	Rearward Limit Inches Aft of Datum
2020	83.8	93.0
1950 (and less)	83.0	93.0

NOTES

Straight line variation between points given.

The datum used is 78.4 inches ahead of the wing leading edge at the inboard intersection of the straight and tapered section.

It is the responsibility of the airplane owner and the pilot to insure that the airplane is properly loaded. See Section 6 (Weight and Balance) for proper loading instructions.

2.15 MANEUVER LIMITS

- (a) Normal Category - All acrobatic maneuvers including spins prohibited.
- (b) Utility Category - Approved Maneuvers for bank angles exceeding 60°.

	Entry Speed
Steep Turns	111 KIAS
Lazy Eights	111 KIAS
Chandelles	111 KIAS

2.17 FLIGHT LOAD FACTORS

- | | | |
|------------------------------------|--------------------------------|---------|
| | Normal | Utility |
| (a) Positive Load Factor (Maximum) | 3.8 G | 4.4G |
| (b) Negative Load Factor (Maximum) | No inverted maneuvers approved | |

2.19 KINDS OF OPERATION EQUIPMENT LIST

This airplane may be operated in day or night VFR, day or night IFR when the appropriate equipment is installed and operable.

The following equipment list identifies the systems and equipment upon which type certification for each kind of operation was predicated and must be installed and operable for the particular kind of operation indicated.

NOTE

The following system and equipment list does not include specific night instruments and communications navigation equipment required by the FAR Part 91 and 135 operating requirements.

System	Number Required	Types of Operation and Remarks (DAY, NIGHT, VFR, and IFR)
1. ELECTRICAL		
Alternator	1	DAY, NIGHT, VFR, IFR
Volt/Ammeter	1	DAY, NIGHT, VFR, IFR
2. EQUIPMENT/ FURNISHINGS		
Safety Restraint Each Occupant	AR	DAY, NIGHT, VFR, IFR

ISSUED: SEPTEMBER 9, 1988
REVISED: SEPTEMBER 12, 1990

REPORT: VB-1360
2-5

**SECTION
LIMITATIONS**

**PIPER AIRCRAFT CORPORATION
PA-28-161, CADET**

2.19 KINDS OF OPERATION EQUIPMENT LIST (Continued)

System	Number Required	Types of Operation and Remarks (DAY, NIGHT, VFR, and IFR)
3. FLIGHT CONTROLS Elevator and Rudder Trim Position Indicator	1 ea.	DAY, NIGHT, VFR, IFR
4. FUEL Fuel Pressure Indicator	1	DAY, NIGHT, VFR, IFR
Fuel Quantity Indicating System	2	DAY, NIGHT, VFR, IFR
5. INSTRUMENTATION - ENGINE Tachometer	1	DAY, NIGHT, VFR, IFR
Oil Pressure Indicator	1	DAY, NIGHT, VFR, IFR
Oil Temperature Indicator	1	DAY, NIGHT, VFR, IFR
6. INSTRUMENTATION - FLIGHT Airspeed Indicator	1	DAY, NIGHT, VFR, IFR
Altimeter	1	DAY, NIGHT, VFR, IFR
Magnetic Compass	1	DAY, NIGHT, VFR, IFR
7. LIGHTS - EXTERNAL Position Lights a. Lift Wing - Red	1 ea.	NIGHT, VFR, IFR
b. Right Wing - Green	1 ea.	NIGHT, VFR, IFR
c. Tail - White	1 ea.	NIGHT, VFR, IFR
Anti-Collision (Strobe) Lights	2 ea.	NIGHT, VFR, IFR
8. LIGHTS - COCKPIT Instrument Lights	AR	NIGHT, VFR, IFR

2.19 KINDS OF OPERATION EQUIPMENT LIST (Continued)

System	Number Required	Types of Operation and Remarks (DAY, NIGHT, VFR, and IFR)
9. PNEUMATIC/ VACUUM		
Vacuum Pump	1	DAY, NIGHT, IFR
Gyro Suction Indicator	1	DAY, NIGHT, IFR

NOTE

The above system and equipment list does not include specific flight instruments and communication/navigation equipment required by the FAR Part 91 and 135 operating requirements.

2.21 FUEL LIMITATIONS

- (a) Total Capacity 50 U.S. GAL
- (b) Unusable Fuel 2 U.S. GAL
The unusable fuel for this airplane has been determined as 1.0 gallon in each wing in critical flight attitudes.
- (c) Usable Fuel 48 U.S. GAL
The usable fuel in this airplane has been determined as 24.0 gallons in each wing.

2.23 PLACARDS

In full view of the pilot:

THIS AIRPLANE MUST BE OPERATED AS A NORMAL OR UTILITY CATEGORY AIRPLANE IN COMPLIANCE WITH THE OPERATING LIMITATIONS STATED IN THE FORM OF PLACARDS, MARKINGS AND MANUALS.

ALL MARKINGS AND PLACARDS ON THIS AIRPLANE APPLY TO ITS OPERATION AS A UTILITY CATEGORY AIRPLANE. FOR NORMAL AND UTILITY CATEGORY OPERATION, REFER TO THE PILOT'S OPERATING HANDBOOK.

NO ACROBATIC MANEUVERS ARE APPROVED FOR NORMAL CATEGORY OPERATIONS. SPINS ARE PROHIBITED FOR NORMAL AND UTILITY CATEGORY.

In full view of the pilot:

TAKEOFF CHECKLIST

Fuel on proper tank	Seat backs erect
Electric fuel pump on	Fasten belts/harness
Engine gauges checked	Trim tab - set
Flaps - set	Controls - free
Carb. heat off	Door - latched
Mixture set	Air conditioner off
Primer locked	

LANDING CHECKLIST

Fuel on proper tank	Flaps - set (White Arc)
Mixture rich	Fasten belts/harness
Electric fuel pump on	Air conditioner off
Seat backs erect	

In air conditioned aircraft, the AIR COND OFF item in the takeoff and landing checklists above, is mandatory.

2.23 PLACARDS (Continued)

In full view of the pilot, in the area of the air conditioner control panel when the air conditioner is installed:

WARNING — AIR CONDITIONER MUST BE OFF
TO INSURE NORMAL TAKEOFF CLIMB PERFORM-
ANCE.

Adjacent to upper door latch:

ENGAGE LATCH BEFORE FLIGHT

In full view of the pilot:

V_A = 111 KIAS AT 2325# (SEE P.O.H.)

UTILITY CATEGORY OPERATION - NO AFT
PASSENGERS ALLOWED.

DEMO. X-WIND 17 KTS.

In full view of the pilot when the oil cooler winterization kit is installed:

OIL COOLER WINTERIZATION PLATE TO BE
REMOVED WHEN AMBIENT TEMPERATURE
EXCEEDS 50° F.

In full view of the pilot:

UTILITY CATEGORY OPERATION ONLY

- (1) NO AFT PASSENGERS ALLOWED.
- (2) ACROBATIC MANEUVERS ARE LIMITED TO
THE FOLLOWING:

SPINS PROHIBITED
STEEP TURNS
LAZY EIGHTS
CHANDELLES

ENTRY SPEED

111 KIAS
111 KIAS
111 KIAS

2.23 PLACARDS (Continued)

In full view of the pilot:

**WARNING — TURN OFF STROBE LIGHTS WHEN
IN CLOSE PROXIMITY TO GROUND OR DURING
FLIGHT THROUGH CLOUD, FOG OR HAZE.**

Adjacent to fuel filler caps:

FUEL - 100 OR 100LL AVIATION GRADE

Adjacent to fuel filler caps:

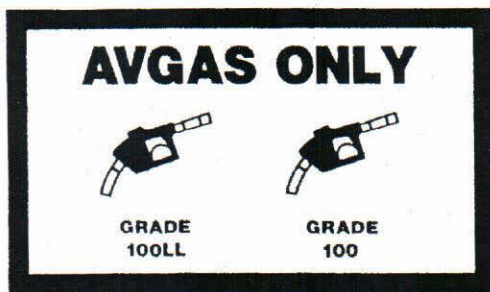

On aft closeout panel:

MAXIMUM BAGGAGE THIS COMPARTMENT 50 LBS

**SEE THE LIMITATIONS SECTION OF
THE PILOTS OPERATING HANDBOOK.**

On floor forward of baggage compartment:

NO BAGGAGE THIS COMPARTMENT

**SEE THE LIMITATIONS SECTION OF
THE PILOTS OPERATING HANDBOOK.**

2.23 PLACARDS (CONTINUED)

On instrument panel near nonfunctional gear select handle (when installed):

GEAR SELECT
NON-FUNCTIONAL
SIMULATOR ONLY

On center support above compass:

CAUTION

COMPASS
CAL. MAY
BE IN ERROR
WITH ELECT.
EQUIPMENT
OTHER THAN
AVIONICS ON

THIS PAGE INTENTIONALLY LEFT BLANK

TABLE OF CONTENTS
SECTION 3
EMERGENCY PROCEDURES

Paragraph No.		Page No.
3.1	General	3-1
3.2	Airspeeds for Safe Operation	3-2
3.3	Emergency Procedures Checklist	3-3
3.3a	Engine Fire During Start (3.7)	3-3
3.3b	Engine Power Loss During Takeoff (3.9)	3-3
3.3c	Engine Power Loss In Flight (3.11)	3-3
3.3d	Power Off Landing (3.13)	3-4
3.3e	Fire In Flight (3.15)	3-4
3.3f	Loss Of Oil Pressure (3.17)	3-5
3.3g	Loss Of Fuel Pressure (3.19)	3-5
3.3h	High Oil Temperature (3.21)	3-5
3.3i	Electrical Failures (3.23)	3-5
3.3j	Electrical Overload (3.25)	3-6
3.3k	Spin Recovery (3.27)	3-6
3.3m	Open Door (3.29)	3-7
3.3n	Engine Roughness (3.31)	3-7
3.3o	Carburetor Icing (3.33)	3-8
3.5	Amplified Emergency Procedures (General)	3-9

TABLE OF CONTENTS

SECTION 3 (cont)

Paragraph No.		Page No.
3.7	Engine Fire During Start (3.3a)	3-9
3.9	Engine Power Loss During Takeoff (3.3b)	3-9
3.11	Engine Power Loss In Flight (3.3c)	3-10
3.13	Power Off Landing (3.3d)	3-10
3.15	Fire In Flight (3.3e)	3-11
3.17	Loss Of Oil Pressure (3.3f)	3-12
3.19	Loss Of Fuel Pressure (3.3g)	3-12
3.21	High Oil Temperature (3.3h)	3-12
3.23	Electrical Failures (3.3i)	3-13
3.25	Electrical Overload (3.3j)	3-13
3.27	Spin Recovery (3.3k)	3-14
3.29	Open Door (3.3m)	3-14
3.31	Engine Roughness (3.3n)	3-14
3.33	Carburetor Icing (3.3o)	3-15

SECTION 3 EMERGENCY PROCEDURES

3.1 GENERAL

This section provides the recommended procedures for coping with various emergency or critical situations. All of the emergency procedures required by the FAA, as well as those necessary for operation of the airplane, as determined by the operating and design features of the airplane, are presented.

Emergency procedures associated with optional systems and equipment which require handbook supplements are presented in Section 9, Supplements.

This section is divided into two basic parts. The first part contains the emergency procedures checklists. These checklists supply an immediate action sequence to be followed during critical situations with little emphasis on the operation of the systems. The numbers located in parentheses after each checklist heading indicate where the corresponding paragraph in the amplified procedures can be found.

The second part of the section provides amplified emergency procedures corresponding to the emergency procedures checklist items. These amplified emergency procedures contain additional information to provide the pilot with a more complete description of the procedures so they may be more easily understood. The numbers located in parentheses after each paragraph heading indicates the corresponding checklist paragraph.

Pilots must familiarize themselves with the procedures given in this section and must be prepared to take the appropriate action should an emergency situation arise. The procedures are offered as a course of action for coping with the particular situation or condition described. They are not a substitute for sound judgment and common sense.

Most basic emergency procedures are a normal part of pilot training. The information presented in this section is not intended to replace the training. This information is intended to provide a source of reference for the procedures which are applicable to this airplane. The pilot should review standard emergency procedures periodically to remain proficient in them.

3.2 AIRSPEEDS FOR SAFE OPERATIONS

3.2a STALL SPEEDS

2325 lbs (0° Flap)	50 KIAS
2325 lbs (Full Flap)	44 KIAS

3.2b MANEUVERING SPEEDS

2325 lbs	111 KIAS
1531 lbs	88 KIAS

3.2c NEVER EXCEED SPEED

Never Exceed Speed	160 KIAS
--------------------------	----------

3.2d POWER OFF GLIDE SPEED

2325 lbs (0° Flap)	73 KIAS
--------------------------	---------

3.3c ENGINE POWER LOSS IN FLIGHT (3.11) (Continued)

Primer CHECK LOCKED
If no fuel pressure is indicated, check tank selector position to be sure it is on a tank containing fuel.

When power is restored:
Carburetor Heat OFF
Electric Fuel Pump OFF

If power is not restored, prepare for power off landing (3.3d).
Trim for 73 KIAS

3.3d POWER OFF LANDING (3.13)

Locate suitable field.
Establish spiral pattern.
1000 ft. above field at downwind position for normal landing approach. When field can easily be reached slow to 63 KIAS for shortest landing.

Touchdowns should normally be made at lowest possible airspeed with full flaps extended.

When committed to landing:
Ignition OFF
BATT MASTR Switch OFF
ALTR Switch OFF
Fuel Selector OFF
Mixture IDLE CUT-OFF
Seat Belts and Harnesses TIGHT

3.3e FIRE IN FLIGHT (3.15)

Source of Fire CHECK

Electrical fire (smoke in cabin):

BATT MASTR Switch OFF
ALTR Switch OFF
Vents OPEN
Cabin Heat OFF
Land as soon as practical.

3.3e FIRE IN FLIGHT (3.15) (Continued)

Engine fire:

Fuel Selector OFF
Throttle CLOSED
Mixture IDLE CUT-OFF
Electric Fuel Pump CHECK OFF
Heater OFF
Defroster OFF
Proceed with POWER OFF LANDING procedure (3.3d).

NOTE

The possibility of an engine fire in flight is extremely remote. The procedure given is general and pilot judgement should be the determining factor for action in such an emergency.

3.3f LOSS OF OIL PRESSURE (3.17)

Land as soon as possible and investigate cause.
Prepare for power off landing (3.3d).

3.3g LOSS OF FUEL PRESSURE (3.19)

Electric Fuel Pump ON
Fuel Selector CHECK on TANK
CONTAINING FUEL

3.3h HIGH OIL TEMPERATURE (3.21)

Land at nearest airport and investigate the problem.
Prepare for power off landing (3.3d).

3.3i ELECTRICAL FAILURES (3.23)

ALT annunciator light illuminated:
Ammeter CHECK to VERIFY inop. alt.

If ammeter shows zero:
ALTR Switch OFF

Reduce electrical loads to minimum:
ALTNTR. FIELD Circuit Breaker CHECK and RESET
as required
ALTR Switch ON

3.3i ELECTRICAL FAILURES (3.23) (Continued)

If power not restored:
ALTR Switch OFF

If alternator output cannot be restored, reduce electrical loads and land as soon as practical. The battery is the only remaining source of electrical power.

3.3j ELECTRICAL OVERLOAD (Alternator over 20 amps above known electrical load) (3.25)

ALTR Switch ON
BATT MASTR Switch OFF

If alternator loads are reduced:
Electrical Load REDUCE to Minimum

Land as soon as practical.

NOTE

Due to increased system voltage and radio frequency noise, operation with ALT switch ON and BATT switch OFF should be made only when required by an electrical system failure.

If alternator loads are not reduced:
ALTR Switch OFF
BATT MASTR Switch AS REQUIRED

Land as soon as possible. Anticipate complete electrical failure.

3.3k SPIN RECOVERY (3.27)

Throttle IDLE
Ailerons NEUTRAL
Rudder FULL OPPOSITE to
DIRECTION of ROTATION
Control Wheel FULL FORWARD
Rudder NEUTRAL (when
rotation stops)
Control Wheel AS REQUIRED to SMOOTHLY
REGAIN LEVEL FLIGHT ALTITUDE

3.3m OPEN DOOR (3.29)

If both upper and lower latches are open, the door will trail slightly open and airspeeds will be reduced slightly.

To close the door in flight:

Slow airplane to 89 KIAS

Cabin Vents CLOSE

Storm Window OPEN

If upper latch is open LATCH

If side latch is open PULL on ARMREST while
moving latch handle to
LATCH position.

If both latches are open LATCH SIDE LATCH
then TOP LATCH.

3.3n ENGINE ROUGHNESS (3.31)

Carburetor Heat ON

If roughness continues after one minute:

Carburetor Heat OFF

Mixture ADJUST for MAXIMUM
SMOOTHNESS

Electric Fuel Pump ON

Fuel Selector SWITCH TANKS

Engine Gauges CHECK

Magneto Switch L then R
then BOTH

If operation is satisfactory on either magneto, continue on that magneto at reduced power and full RICH mixture to first airport.

Prepare for power off landing (3.3d).

NOTE

Partial carburetor heat may be worse than no heat at all, since it may melt part of the ice which will refreeze in the intake system. Therefore, when using carburetor heat always use full heat; and, when ice is removed, return the control to the full cold position.

3.3o CARBURETOR ICING (3.33)

Carburetor Heat ON
Mixture ADJUST for MAXIMUM
SMOOTHNESS

3.5 AMPLIFIED EMERGENCY PROCEDURES (GENERAL)

The following paragraphs are presented to supply additional information for the purpose of providing the pilot with a more complete understanding of the recommended course of action and probable cause of an emergency situation.

3.7 ENGINE FIRE DURING START (3.3a)

Engine fires during start are usually the result of overpriming. The first effort to extinguish the fire is to attempt an engine start in order to draw the excess fuel back into the induction system.

If a fire is present before the engine has started, try to draw the fire back into the engine by moving the mixture control to idle cut-off, opening the throttle, turning OFF the electric fuel pump and fuel selector, while cranking the engine.

If an external fire extinguishing method is used, set the mixture control to idle cut-off, and turn OFF the electric fuel pump and fuel selector.

3.9 ENGINE POWER LOSS DURING TAKEOFF (3.3b)

The proper action to be taken if loss of power occurs during takeoff will depend on the circumstances of the particular situation.

If sufficient runway remains to complete a normal landing, land straight ahead.

If insufficient runway remains, maintain a safe airspeed and make only a shallow turn if necessary to avoid obstructions. Use of flaps depends on the circumstances. Normally, flaps should be fully extended for touchdown.

If sufficient altitude has been gained to attempt a restart, maintain a safe airspeed and switch the fuel selector to another tank containing fuel. Check the electric fuel pump to ensure that it is ON and that the mixture is RICH. The carburetor heat should be ON and the primer locked.

If engine failure was caused by fuel exhaustion, power will not be regained after switching the fuel tanks until the empty fuel lines are filled. This may require up to ten seconds.

If power is not regained, proceed with the Power Off Landing procedure (refer to the emergency checklist (3.3d) and paragraph 3.13).

3.11 ENGINE POWER LOSS IN FLIGHT (3.3e)

Complete engine power loss is usually caused by fuel flow interruption, and power will be restored shortly after fuel flow is restored. If power loss occurs at a low altitude, the first step is to prepare for an emergency landing (refer to paragraph 3.13). Trim the airplane for best gliding angle (73 KIAS), and look for a field suitable for landing.

If altitude permits, switch the fuel selector to another tank containing fuel and turn the electric fuel pump ON. Move the mixture control to RICH and the carburetor heat to ON. Check the engine gauges for an indication of the cause of the power loss. Check to ensure the primer is locked. If no fuel pressure is indicated, check the tank selector position to be sure it is on a tank containing fuel.

When power is restored move the carburetor heat to the OFF position and turn OFF the electric fuel pump.

If the preceding steps do not restore power, prepare for an emergency landing.

If time permits, turn the ignition switch to L then to R then back to BOTH. Move the throttle and mixture control levers to different settings. This may restore power if the problem is too rich or too lean a mixture or if there is a partial fuel system restriction. Try other fuel tanks. Water in the fuel could take some time to be used up, and allowing the engine to windmill may restore power. If power loss is due to water, fuel pressure indications will be normal.

If engine failure was caused by fuel exhaustion, power will not be restored after switching fuel tanks until the empty fuel lines are filled. This may require up to ten seconds.

If power is not regained, proceed with the Power Off Landing procedure (refer to the emergency checklist (3.3d) and paragraph 3.13).

3.13 POWER OFF LANDING (3.3d)

If loss of power occurs at altitude, trim the aircraft for best gliding angle (73 KIAS) and look for a suitable field. If measures taken to restore power are not effective, and if time permits, check your charts for airports in the immediate vicinity; it may be possible to land at one if you have sufficient altitude. If possible, notify the FAA by radio of your difficulty and intentions. If another pilot or passenger is aboard, let him help.

3.13 POWER OFF LANDING (3.3d) (Continued)

When a suitable field has been located, establish a spiral pattern around it. To make a normal landing approach, try to be at 1000 feet above the field at the downwind position. When the field can easily be reached, slow to 63 KIAS for the shortest landing. Excess altitude may be lost by widening the pattern, using flaps, slipping, or a combination of these.

When committed to a landing, turn OFF the battery master (BATT MASTR), alternator (ALTR), and ignition switches. Flaps may be used as desired. Turn the fuel selector valve to OFF and move the mixture to idle cut-off. The seat belts and shoulder harnesses should be tightened. Touchdown should normally be made at the lowest possible airspeed with full flaps extended.

3.15 FIRE IN FLIGHT (3.3e)

Because the necessary course of action differs somewhat in each case, it is essential that the source of the fire be identified promptly through instrument readings, characteristics of the smoke, or other indications.

First check for the source of the fire.

If smoke in the cabin indicates an electrical fire, turn the battery master (BATT MASTR) and alternator (ALTR) switches OFF, open the cabin vents, and turn the cabin heat OFF. A landing should be made as soon as possible.

If an engine fire exists, switch the fuel selector OFF and close the throttle. Set the mixture to idle cut-off and turn the electric fuel pump OFF. In all cases, the heater and defroster should be OFF. If radio communication is not required, select the battery master and alternator switches OFF. Proceed with Power Off Landing procedure (refer to paragraph 3.13).

NOTE

The possibility of an engine fire in flight is extremely remote. The procedure given is general and pilot judgement should be the determining factor for action in such an emergency.

3.17 LOSS OF OIL PRESSURE (3.3f)

Loss of oil pressure may be either partial or complete. A partial loss of oil pressure usually indicates a malfunction in the oil pressure regulating system, and a landing should be made as soon as possible to investigate the cause and prevent engine damage.

A complete loss of oil pressure indication may signify oil exhaustion or may be the result of a faulty gauge. In either case, proceed toward the nearest airport, and be prepared for a forced landing. Since the engine may stop suddenly, if the problem is *not* a pressure gauge malfunction, maintain altitude until such time as a dead stick landing can be accomplished. Don't change power settings unnecessarily, as this may hasten complete power loss.

Depending on the circumstances, it may be advisable to make an off airport landing while power is still available, particularly if other indications of actual oil pressure loss, such as sudden increases in temperatures, or oil smoke, are apparent, and an airport is not close.

If engine stoppage occurs, proceed with a power off landing (refer to paragraph 3.13).

33.19 LOSS OF FUEL PRESSURE (3.3g)

If loss of fuel pressure occurs, turn ON the electric fuel pump and check that the fuel selector is on a tank containing fuel.

If the problem is not an empty tank, land as soon as practical and have the engine-driven fuel pump and fuel system checked.

3.21 HIGH OIL TEMPERATURE (3.3h)

An abnormally high oil temperature indication may be caused by a low oil level, an obstruction in the oil cooler, damaged or improper baffle seals, a defective gauge, or other causes. Land as soon as practical at an appropriate airport and have the cause investigated.

A steady, rapid rise in oil temperature is a sign of trouble. Land at the nearest airport and let a mechanic investigate the problem. Watch the oil pressure gauge for an accompanying loss of pressure.

3.23. ELECTRICAL FAILURES (3.3i)

Loss of alternator output is detected through zero reading on the ammeter. Before executing the following procedure, ensure that the reading is zero, and not merely low, by actuating an electrically powered device, such as the landing light. If no increase in the ammeter reading is noted, alternator failure can be assumed.

The electrical load should be reduced as much as possible. Check for an open alternator field circuit breaker.

Next attempt to reset the overvoltage relay by moving the ALTR switch to OFF for one second and then to ON. If the trouble was caused by a momentary overvoltage condition (16.5 volts and up) this procedure should return the ammeter to a normal reading.

If the ammeter continues to indicate ZERO output, or if the alternator will not remain reset, turn off the ALTR switch, maintain minimum electrical load and land as soon as practical. All electrical load is being supplied by the battery.

3.25 ELECTRICAL OVERLOAD (Alternator over 20 amps above known electrical load) (3.3j)

If abnormally high alternator output is observed (more than 20 amps above known electrical load for the operating conditions), it may be caused by a low battery, a battery fault or other abnormal electrical load. If the cause is a low battery, the indication should begin to decrease toward normal within 5 minutes. If the overload condition persists, attempt to reduce the load by turning off nonessential equipment.

Turn the BATT MASTR switch OFF and the ammeter should decrease. Turn the BATT MASTR switch ON and continue to monitor the ammeter. If the alternator output does not decrease within 5 minutes, turn the BATT MASTR switch OFF and land as soon as possible. All electrical loads are being supplied by the alternator.

NOTE

Due to increased system voltage and radio frequency noise, operation with the ALTR switch ON and the BATT MASTR switch OFF should be made only when required by an electrical failure.

3.27 SPIN RECOVERY (3.3k)

Intentional spins are prohibited in this airplane. If a spin is inadvertently entered, immediately move the throttle to idle and the ailerons to neutral.

Full rudder should then be applied opposite to the direction of rotation followed by control wheel full forward. When the rotation stops, neutralize the rudder and ease back on the control wheel as required to smoothly regain a level flight attitude.

3.29 OPEN DOOR (3.3m)

The Cadet's cabin door is double latched, so the chance of it opening at both the top and bottom in flight are remote. However, should the upper latch not be closed, or the side latch not be fully engaged, the door may spring partially open at takeoff or soon afterward.

If both the upper and side latches have not been engaged, the door will trail slightly open, resulting in unpleasant air and propeller noise, and a slight reduction in airspeed. A partially open door will not affect normal flight characteristics, and a normal landing can be made.

To close the door in flight, slow the airplane to 89 KIAS, close the cabin vents and open the storm window. If the top latch is open, latch it. If the side latch is open, pull on the armrest while moving the latch handle to the latched position. If both latches are open, close the side latch first, and then the top latch.

3.31 ENGINE ROUGHNESS (3.3n)

Engine roughness is usually due to carburetor icing which is indicated by a drop in rpm, and may be accompanied by a slight loss of airspeed or altitude. If too much ice is allowed to accumulate, restoration of full power may not be possible; therefore, prompt action is required.

Turn carburetor heat on (see Note). Rpm will decrease slightly and roughness will increase. Wait for a decrease in engine roughness or an increase in rpm, indicating ice removal. If there is no change in approximately one minute, return the carburetor heat to OFF.

3.31 ENGINE ROUGHNESS (3.3n) (Continued)

If the engine is still rough, adjust the mixture for maximum smoothness. The engine will run rough if the mixture is too rich or too lean. The electric fuel pump should be switched to ON and the fuel selector switched to the other tank to see if fuel contamination is the problem. Check the engine gauges for abnormal readings. If any gauge readings are abnormal, proceed accordingly. Move the magneto switch to L then to R, then back to BOTH. If operation is satisfactory on either magneto, proceed on that magneto, at reduced power, with mixture full RICH, to a landing at the first available airport.

If roughness persists, prepare for a precautionary landing at pilot's discretion.

NOTE

Partial carburetor heat may be worse than no heat at all, since it may melt part of the ice which will refreeze in the intake system. Therefore, when using carburetor heat always use full heat; and, when ice is removed, return the control to the full cold position.

3.33 CARBURETOR ICING (3.3o)

Under certain moist atmospheric conditions at temperatures of -5°C to 20°C , it is possible for ice to form in the induction system, even in summer weather. This is due to the high air velocity through the carburetor venturi and absorption of heat from this air by vaporization of the fuel.

To avoid this, carburetor preheat is provided to replace the heat lost by vaporization. Carburetor heat should be full on when carburetor ice is encountered. Adjust mixture for maximum smoothness.

THIS PAGE INTENTIONALLY LEFT BLANK

TABLE OF CONTENTS
SECTION 4
NORMAL PROCEDURES

Paragraph No.		Page No.
4.1	GENERAL	4-1
4.3	AIRSPED FOR SAFE OPERATIONS	4-2
4.5	NORMAL PROCEDURES CHECKLIST	4-3
4.5a	Preparation (4.9)	4-3
4.5b	Preflight Checklist (4.11)	4-4
4.5c	Before Starting Engine Checklist (4.13).....	4-6
4.5d	Engine Start Checklist (4.15)	4-6
	NORMAL START - COLD ENGINE (4.15a).....	4-6
	NORMAL START - HOT ENGINE (4.15b)	4-7
	ENGINE START WHEN FLOODED (4.15c).....	4-7
	ENGINE START WITH EXTERNAL POWER SOURCE (4.15d).....	4-7
4.5e	Warm-Up Checklist (4.17)	4-8
4.5f	Taxiing Checklist (4.19)	4-8
4.5g	Ground Check Checklist (4.21)	4-8
4.5h	Before Takeoff Checklist (4.23)	4-9

TABLE OF CONTENTS

SECTION 4 (cont)

Paragraph No.		Page No.
4.5i	Takeoff Checklist (4.25)	4-10
	NORMAL (4.25a)	4-10
	0° FLAPS TAKEOFF PERFORMANCE (4.25b) .	4-10
	25° FLAPS TAKEOFF PERFORMANCE (4.25c)	4-10
	SOFT FIELD, OBSTACLE CLEARANCE (4.25d)	4-10
	SOFT FIELD NO OBSTACLE (4.25e).....	4-11
4.5j	Climb Checklist (4.27)	4-11
4.5k	Cruise Checklist (4.29)	4-11
4.5m	Descent Checklist (4.31)	4-11
	NORMAL DESCENT (4.31a).....	4-11
	POWER OFF DESCENT (4.31b)	4-12
4.5n	Approach And Landing Checklist (4.33)	4-12
4.5o	Stopping Engine Checklist (4.35)	4-12
4.5p	Mooring Checklist (4.37)	4-13
4.7	AMPLIFIED NORMAL PROCEDURES (GENERAL).	4-15
4.9	PREPARATION (4.5a)	4-15
4.11	PREFLIGHT CHECK (4.5b)	4-15
4.11a	Cockpit (4.5b)	4-15
4.11b	Right Wing (4.5b)	4-16

TABLE OF CONTENTS

SECTION 4 (cont)

Paragraph No.		Page No.
4.11c	Nose Section (4.5b)	4-16
4.11d	Left Wing (4.5b).....	4-17
4.11e	Fuselage (4.5b)	4-17
4.13	BEFORE STARTING ENGINE (4.5c)	4-18
4.15	ENGINE START (4.5d).....	4-18
4.15a	Normal Start - Cold Engine (4.5d)	4-18
4.15b	Normal Start - Hot Engine (4.5d)	4-19
4.15c	Engine Start When Flooded (4.5d)	4-19
4.15d	Engine Start With External Power Source (4.5d).....	4-19
4.17	WARM-UP (4.5e)	4-20
4.19	TAXIING (4.5f).....	4-20
4.21	GROUND CHECK (4.5g)	4-21
4.23	BEFORE TAKEOFF (4.5h)	4-22
4.25	TAKEOFF (4.5i)	4-23
4.25a	Normal (4.5i)	4-23
4.25b	0° Flaps Takeoff Performance (4.5i)	4-23
4.25c	25° Flaps Takeoff Performance (4.5i)	4-23
4.25d	Soft Field, Obstacle Clearance (4.5i)	4-23
4.25e	Soft Field, No Obstacle (4.5i)	4-24

TABLE OF CONTENTS

SECTION 4 (cont)

Paragraph No.		Page No.
4.27	CLIMB (4.5j)	4-24
4.29	CRUISE (4.5k)	4-24
4.31	DESCENT (4.5m)	4-25
4.31a	Normal Descent (4.5m)	4-25
4.31b	Power Off Descent (4.5m)	4-26
4.33	APPROACH AND LANDING (4.5n)	4-26
4.35	STOPPING ENGINE (4.5o)	4-27
4.37	MOORING (4.5p)	4-28
4.39	STALLS	4-28
4.41	TURBULENT AIR OPERATION	4-28
4.43	WEIGHT AND BALANCE	4-29
4.45	NOISE LEVEL	4-29

SECTION 4

NORMAL PROCEDURES

4.1 GENERAL

This section provides the normal operating procedures for the PA-28-161, Cadet airplane. All of the normal operating procedures required by the FAA, as well as those procedures which have been determined as necessary for the operation of the airplane, as determined by the operating and designed features of the airplane, are presented.

Normal operating procedures associated with optional systems and equipment which require handbook supplements are presented in Section 9, Supplements.

These procedures are provided to supply information on procedures which are not the same for all airplanes and as a source of reference and review. Pilots should familiarize themselves with the procedures to become proficient in the normal operations of the airplane.

This section is divided into two parts. The first part is a short form checklist supplying an action - reaction sequence for normal procedures with little emphasis on the operation of the systems. Numbers in parentheses after each checklist section indicate the paragraph where the corresponding amplified procedure can be found.

The second part of this section contains the amplified normal procedures which provide detailed information and explanations of the procedures and how to perform them. This portion of the section is not intended for use as an inflight reference due to the lengthy explanations. The short form checklists should be used on the ground and in flight. Numbers in parentheses after each paragraph title indicate where the corresponding checklist can be found.

4.3 AIRSPEEDS FOR SAFE OPERATIONS

The following airspeeds are those which are significant to the operation of the airplane. These figures are for standard airplanes flown at gross weight under standard conditions at sea level.

Performance for a specific airplane may vary from published figures depending upon the equipment installed; the condition of the engine, airplane and equipment; atmospheric conditions and piloting technique.

(a) Best Rate of Climb Speed	79 KIAS
(b) Best Angle of Climb Speed	63 KIAS
(c) Turbulent Air Operating Speed (See Subsection 2.3)	111 KIAS
(d) Maximum Flap Speed	103 KIAS
(e) Landing Final Approach Speed (Flaps 40°)	63 KIAS
(f) Maximum Demonstrated Crosswind Velocity	17 KTS

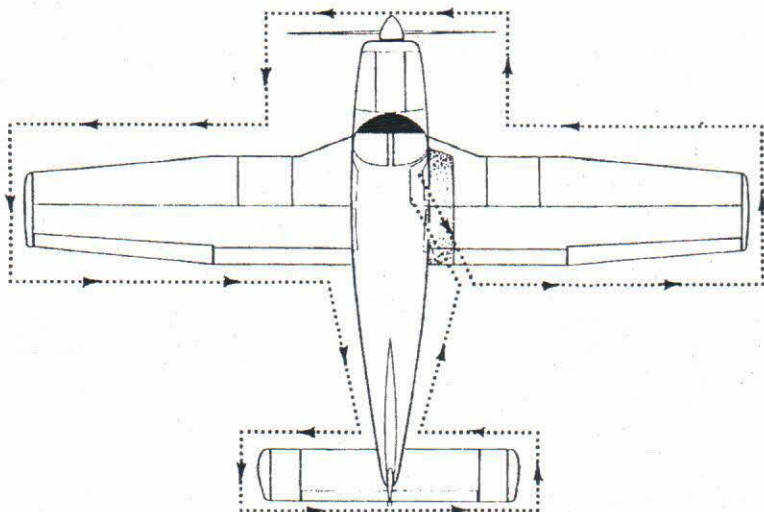

WALK-AROUND

Figure 4-1

4.5 NORMAL PROCEDURES CHECKLIST

4.5a Preparation (4.9)

Airplane Status	AIRWORTHY, PAPERS ON BOARD
Weather	SUITABLE
Baggage	WEIGHED, STOWED, TIED
Weight and C.G.	WITHIN LIMITS
Navigation	PLANNED
Charts and Navigation Equipment	ON BOARD
Performance and Range	COMPUTED AND SAFE

CAUTION

The flap position should be noted before boarding the airplane. The flaps must be placed in the UP position before they will lock and support weight on the step.

4.5b Preflight Checklists (4.11)

COCKPIT (4.11a)

Control Wheel RELEASE BELTS
Circuit Breakers IN
Avionics OFF
Parking Brake SET
Electric Switches OFF
Magneto Switch OFF
Mixture IDLE CUT-OFF
BATT MASTR Switch ON
Fuel Quantity Gauges CHECK
Annunciator Panel CHECK
BATT MASTR Switch OFF
Flight Controls CHECK
Flaps CHECK
Trim CHECK, SET NEUTRAL
Pitot Drain DRAIN, CLOSE
Static Drain DRAIN, CLOSE
Windows CHECK, CLEAN
Tow Bar STOW
Baggage SECURE

RIGHT WING (4.11b)

Wing FREE of ICE, SNOW, FROST
Control Surfaces CHECK for interference -
CLEAR of ICE, SNOW, FROST
Hinges CHECK for interference
Static Wicks CHECK
Wing Tip and Lights CHECK
Fuel Tank CHECK supply
visually - SECURE CAPS

CAUTION

When draining any amount of fuel, care should be taken to ensure that no fire hazard exists before starting engine.

Fuel Tank Sump DRAIN, CHECK for water,
sediment and proper fuel
Fuel Vent CLEAR
Tie Down and Chock REMOVE

4.5b Preflight Checklists (4.11) (Continued)

RIGHT WING (4.11b) (Continued)

Main Gear Strut PROPER
INFLATION (4.50 in.)
Tire CHECK
Brake Block and Disc CHECK
Fresh Air Inlet CLEAR

NOSE SECTION (4.11c)

Fuel and Oil CHECK FOR LEAKS
Cowling SECURE
Windshield CLEAN
Propeller and Spinner CHECK
Air Inlets CLEAR
Alternator Belt CHECK TENSION
Landing Light CHECK
Nose Chock REMOVE
Nose Gear Strut PROPER
INFLATION (3.25 in.)
Nose Wheel Tire CHECK
Oil CHECK LEVEL
Dipstick PROPERLY SEATED
Fuel Strainer DRAIN, CHECK for water,
sediment and proper fuel

LEFT WING (4.11d)

Wing FREE of ICE, SNOW, FROST
Fresh Air Inlet CLEAR
Main Gear Strut PROPER
INFLATION (4.50 in.)
Tire CHECK
Brake Block and Disc CHECK
Fuel Tank Sumps DRAIN, CHECK for water,
sediment and proper fuel
Fuel Vent CLEAR
Tie Down and Chock REMOVE
Fuel Tanks CHECK supply
visually - SECURE CAPS
Pitot/Static Head REMOVE COVER -
HOLES CLEAR
Wing Tip and Lights CHECK
Control Surfaces CHECK for interference -
FREE of ICE, SNOW, FROST

4.5b Preflight Checklists (4.11) (Continued)

LEFT WING (4.11d) (Continued)

Hinges CHECK for interference
Static Wicks CHECK

FUSELAGE (4.11e)

Antennas CHECK
Empennage FREE of ICE, SNOW, FROST
Fresh Air Inlet CLEAR
Stabilator and Trim Tab CHECK for interference
Tie Down REMOVE
BATT MASTR Switch ON
Cockpit Lighting CHECK
Nav and Strobe Lights CHECK
Stall Warning CHECK
Pitot Heat CHECK
All Switches OFF
Passengers BOARD
Cabin Door CLOSE and SECURE
Seat Belts and Harnesses FASTEN - CHECK
interia reel

4.5c. Before Starting Engine Checklist (4.13)

BEFORE STARTING ENGINE (4.13)

Brakes SET
Carburetor Heat FULL OFF
Fuel Selector DESIRED TANK
Avionics OFF
ALTR Switch ON

4.5d Engine Start Checklist (4.15)

NORMAL START - COLD ENGINE (4.15a)

Throttle ¼ INCH OPEN
BATT MASTR Switch ON
Electric Fuel Pump ON
Mixture FULL RICH
Starter ENGAGE
Throttle ADJUST
Oil Pressure CHECK

If engine does not start within 10 sec., prime and repeat starting procedure.

4.5d Engine Start Checklist (4.15) (Continued)

NORMAL START - HOT ENGINE (4.15b)

Throttle ½ INCH OPEN
BATT MASTR Switch ON
Electric Fuel Pump ON
Mixture FULL RICH
Starter ENGAGE
Throttle ADJUST
Oil Pressure CHECK

ENGINE START WHEN FLOODED (4.15c)

Throttle OPEN FULL
BATT MASTR Switch ON
Electric Fuel Pump OFF
Mixture IDLE CUT-OFF
Starter ENGAGE
Mixture ADVANCE
Throttle RETARD
Oil Pressure CHECK

ENGINE START WITH EXTERNAL POWER SOURCE (4.15d)

BATT MASTR Switch OFF
All Electrical Equipment OFF
Terminals CONNECT
External Power Plug INSERT in
receptacle

NOTE

For all normal operations using the PEP jumper cables, the battery master switch should be OFF. However, it is possible to use the ship's battery in parallel by turning the battery master switch ON. This will give longer cranking capabilities, but will not increase the amperage.

CAUTION

Care should be exercised, because, if the ship's battery has been depleted, the external power supply can be reduced to the level of the ship's battery. This can be tested by turning the battery master switch ON momentarily while the starter is engaged. If cranking speed increases, the ship's battery is at a higher level than the external power supply.

4.5d Engine Start Checklist (4.15) (Continued)

ENGINE START WITH EXTERNAL POWER SOURCE (4.15d)
(Continued)

Proceed with normal start

Throttle LOWEST POSSIBLE
RPM
External Power Plug DISCONNECT from
receptacle
BATT MASTR Switch ON - CHECK AMMETER
Oil Pressure CHECK

4.5e Engine Warm-Up Checklist (4.17)

ENGINE WARM-UP (4.17)

Throttle 800 to 1200 RPM

4.5f Taxiing Checklist (4.19)

TAXIING (4.19)

Parking Brake RELEASE
Taxi Area CLEAR
Throttle APPLY SLOWLY
Brakes CHECK
Steering CHECK

4.5g Ground Check Checklist (4.21)

GROUND CHECK (4.21)

Parking Brake SET
Throttle 2000 RPM
Magnetos max. drop 175 RPM
-max. diff. 50 RPM
Vacuum 4.8 to 5.1 in. Hg
Oil Temperature CHECK
Oil Pressure CHECK
Air Conditioner CHECK
Annunciator Panel PRESS-TO-TEST
Carburetor Heat CHECK

Engine is warm for takeoff when throttle can be opened without engine faltering.

4.5g Ground Check Checklist (4.21) (Continued)

GROUND CHECK (4.21) (Continued)

Electric Fuel Pump OFF
Fuel Pressure CHECK
Throttle RETARD

4.5h Before Takeoff Checklist (4.23)

BEFORE TAKEOFF (4.23)

Battery Master Switch ON
Alternator Switch ON
Flight Instruments CHECK
Fuel Selector PROPER TANK
Electric Fuel Pump ON
Engine Gauges CHECK
Carburetor Heat OFF
Seat Backs ERECT

NOTE

The mixture should be set FULL RICH, but a minimum amount of leaning is permitted for smooth engine operation when taking off at high elevation.

Mixture SET
Primer LOCK

NOTE

The inertia reel type shoulder harness should be given a pull test to check its locking restraint feature.

NOTE

If the fixed shoulder harness (non-inertial reel type) are installed for the aft seat occupants they should be adjusted to provide adequate restraint.

4.5i Takeoff Checklist (4.25) (Continued)

SOFT FIELD, OBSTACLE CLEARANCE (4.25d)

Flaps 25° (second notch)

Accelerate and lift off nose gear as soon as possible. Lift off at lowest possible airspeed. Accelerate just above ground to 52 KIAS to climb past obstacle height. Continue climbing while accelerating to best rate of climb speed, 79 KIAS.

Flaps RETRACT SLOWLY

SOFT FIELD, NO OBSTACLE (4.25e)

Flaps 25° (second notch)

Accelerate and lift off nose gear as soon as possible. Lift off at lowest possible airspeed. Accelerate just above ground to best rate of climb speed, 79 KIAS.

Flaps RETRACT SLOWLY

4.5j Climb Checklist (4.27)

CLIMB (4.27)

Best Rate Climb Speed (Flaps Up) 79 KIAS
Best Angle Climb Speed (Flaps Up) 63 KIAS
En Route 87 KIAS
Electric Fuel Pump OFF at
desired altitude

4.5k Cruise Checklist (4.29)

CRUISE

Reference performance charts and Avco-Lycoming Operators Manual.

Normal Maximum Power 75%
Power SET per power table
Mixture ADJUST

4.5m Descent Checklist (4.31)

NORMAL DESCENT (4.31a)

Throttle 2500 rpm
Airspeed 126 KIAS
Mixture RICH
Carburetor Heat ON if required

POWER OFF DESCENT (4.31b)

Carburetor Heat ON if required
Throttle CLOSE
Airspeed AS REQUIRED
Mixture AS REQUIRED
Power VERIFY with throttle
EVERY 30 SECONDS

4.5n Approach And Landing Checklist (4.33)

APPROACH AND LANDING (See charts in Section 5) (4.33)

Fuel Selector PROPER TANK
Seat Backs ERECT
Belts/ Harness FASTEN/CHECK

NOTE

If the fixed shoulder harness (non-inertia reel type) is installed, it must be connected to the seat belt and adjusted to allow proper accessibility to all controls including fuel selector, flaps, trim, etc, while maintaining adequate restraint for the occupant.

NOTE

If the inertia reel type shoulder harness is installed, a pull test of its locking restraint feature should be performed.

Electric Fuel Pump ON
Mixture SET

4.5n Approach And Landing Checklist (4.33) (Continued)

APPROACH AND LANDING (See charts in Section 5) (4.33)
(Continued)

Flaps SET - 103 KIAS
MAXIMUM
Air Conditioner OFF
Trim to 70 KIAS
Final Approach Speed (Flaps 40°) 63 KIAS

4.5o Stopping Engine Checklist (4.35)

STOPPING ENGINE (4.35)

Flaps RETRACT
Electric Fuel Pump OFF
Electrical Switches OFF
Air Conditioner OFF
Radios OFF
Throttle FULL AFT
Mixture IDLE CUT-OFF
Magnetos OFF
ALTR Switch OFF
BATT MASTR Switch OFF
Trim SET

NOTE

When alternate fuels are used, the engine should be run up to 1200 rpm for one minute prior to shutdown to clean out any unburned fuel.

NOTE

The flaps must be placed in the UP position for the flap step to support weight. Passengers should be cautioned accordingly.

4.5p Mooring Checklist (4.37)

MOORING (4.37)

Parking Brake SET
Control Wheel SECURE with belts
Flaps FULL UP
Wheel Chocks IN PLACE
Tie Downs SECURE

THIS PAGE INTENTIONALLY LEFT BLANK

4.7 AMPLIFIED NORMAL PROCEDURES (GENERAL)

The following paragraphs are provided to supply detailed information and explanations of the normal procedures necessary for the safe operation of the airplane.

4.9 PREPARATION (4.5a)

The airplane should be given a thorough preflight and walk-around check. The preflight should include a check of the airplane's required papers, operational status, computation of weight and C.G. limits, takeoff and landing distances, and in-flight performance. A weather briefing should be obtained for the intended flight path, and any other factors relating to a safe flight should be checked before takeoff.

CAUTION

The flap position should be noted before boarding the airplane. The flaps must be placed in the UP position before they will lock and support weight on the step.

4.11 PREFLIGHT CHECK (4.5b)

4.11a Cockpit (4.5b)

Upon entering the cockpit, release the seat belts securing the control wheel, check that all circuit breakers are in, turn OFF all avionics equipment, and set the parking brake. Ensure that all electrical switches and the magneto switch are OFF and that the mixture is in idle cut-off. Turn ON the battery master (BATT MASTR) switch, check the fuel quantity gauges for adequate supply and check that the annunciator panel illuminates. Turn OFF the battery master (BATT MASTR) switch. Check the primary flight controls and flaps for proper operation and set the trim to neutral. Open the pitot and static drains to remove any moisture that has accumulated in the lines. Check the windows for cleanliness. Properly stow the tow bar and baggage and secure.

4.11b Right Wing (4.5b)

Begin the walk-around at the trailing edge of the right wing by checking that the wing surface and control surfaces are clear of ice, frost, snow or other extraneous substances. Check the flap, aileron and hinges for damage and operational interference. Static wicks should be firmly attached and in good condition. Check the wing tip and lights for damage.

Open the fuel cap and visually check the fuel color and the quantity should match the indication that was on the fuel quantity gauge, replace cap securely. The fuel tank vent should be clear of obstructions.

Drain the fuel tank through the quick drain located at the lower inboard rear corner of the tank, making sure that enough fuel has been drained to ensure that all water and sediment is removed. The fuel system should be drained daily prior to the first flight and after each refueling and checked for proper fuel.

CAUTION

When draining any amount of fuel, care should be taken to insure that no fire hazard exists before starting engine.

Remove the tie down and chock.

Next, check the landing gear. Check the gear strut for proper inflation; there should be 4.50 +/- 0.25 inches of strut exposure under a normal static load. Check the tire for cuts, wear, and proper inflation. Make a visual check of the brake block and disc.

Check that the fresh air inlet is clear of foreign matter.

4.11c Nose Section (4.5b)

Check the general condition of the nose section, look for oil or fluid leakage and that the cowling is secure. Check the windshield and clean if necessary. The propeller and spinner should be checked for detrimental nicks, cracks, or other defects. The air inlets should be clear of obstructions and check the alternator belt for proper tension. The landing light should be clean and intact.

4.11c Nose Section (4.5b) (Continued)

Remove the chock and check the nose gear strut for proper inflation, there should be 3.25 +/- 0.25 inches of strut exposure under a normal static load. Check the tire for cuts, wear, and proper inflation. Check the engine baffle seals. Check the oil level, make sure that the dipstick has been properly seated.

Open the fuel strainer located on the left side of the firewall long enough to remove any accumulation of water and sediment and check for proper fuel.

4.11d Left Wing (4.5b)

The wing surface should be clear of ice, frost, snow, or other extraneous substances. Check that the fresh air inlet is clear of foreign matter and remove the chock. Check the main gear strut for proper inflation, there should be 4.50 +/- 0.25 inches of strut exposure under a normal static load. Check the tire and the brake block and disc.

Open the fuel cap and visually check the fuel color. The quantity should match the indication on the fuel quantity gauge. Replace cap securely. The fuel tank vent should be clear of obstructions. Drain enough fuel to ensure that all water and sediment has been removed and check for proper fuel.

Remove tie down and chock. Remove the cover from the pitot/static head on the underside of the wing. Make sure the holes are open and clear of obstructions. Check the wing tip and lights for damage. Check the aileron, flap, and hinges for damage and operational interference and that the static wicks are firmly attached and in good condition.

4.11e Fuselage (4.5b)

Check the condition and security of the antennas. The empennage should be clear of ice, frost, snow, or other extraneous substances, and the fresh air inlet on the side of fuselage should be clear of foreign matter. Check the stabilator and trim tab for damage and operational interference. The trim tab should move in the same direction as the stabilator. Remove the tie down.

4.11e Fuselage (4.5b) (Continued)

Upon returning to the cockpit, an operational check of the interior lights, exterior lights, stall warning system, and pitot heat should now be made. Turn the battery master switch and other appropriate switches ON. Check the panel lighting and the overhead flood light. Visually confirm that exterior lights are operational. Lift the stall detector on the leading edge of the left wing and determine that the warning horn is activated. With the pitot heat switch ON, the pitot head will be hot to the touch. After these checks are complete, the master switch and all electrical switches should be turned OFF.

Board the passengers and close and secure the cabin door. Fasten the seat belts and shoulder harnesses. Pull test the locking restraint feature of the shoulder harness inertia reel. Fasten seat belts on empty seats.

4.13 BEFORE STARTING ENGINE (4.5c)

Before starting the engine the brakes should be set ON and the carburetor heat lever moved to the full OFF position. The fuel selector should then be moved to the desired tank. Check to make sure that all the avionics are OFF. Place the alternator switch in the ON position.

4.15 ENGINE START (4.5d)

4.15a Normal Start - Cold Engine (4.5d)

Open the throttle lever approximately $\frac{1}{4}$ inch. Turn ON the battery master switch and the electric fuel pump.

Move the mixture control to full RICH and engage the starter by rotating the magneto switch clockwise. When the engine fires, release the magneto switch, and move the throttle to the desired setting.

If the engine does not fire within five to ten seconds, disengage the starter, prime the engine and repeat the starting procedure.

4.15b Normal Start - Hot Engine (4.5d)

Open the throttle approximately $\frac{1}{2}$ inch. Turn ON the battery master switch and the electric fuel pump. Move the mixture control lever to full RICH and engage the starter by rotating the magneto switch clockwise. When the engine fires, release the magneto switch and move the throttle to the desired setting.

4.15c Engine Start When Flooded (4.5d)

The throttle lever should be full OPEN. Turn ON the battery master switch and turn OFF the electric fuel pump. Move the mixture control lever to idle cut-off and engage the starter by rotating the magneto switch clockwise. When the engine fires, release the magneto switch, advance the mixture and retard the throttle.

4.15d Engine Start With External Power Source (4.5d)

An optional feature called the Piper External Power (PEP) allows the operator to use an external battery to crank the engine without having to gain access to the airplane's battery.

Turn the battery master (BATT MASTR) switch OFF and turn all electrical equipment OFF. Connect the RED lead of the PEP kit jumper cable to the POSITIVE (+) terminal of an external 12-volt battery and the BLACK lead to the NEGATIVE (-) terminal. Insert the plug of the jumper cable into the socket located on the fuselage. Note that when the plug is inserted, the electrical system is ON. Proceed with the normal starting technique.

After the engine has started reduce power to the lowest possible rpm and disconnect the jumper cable from the aircraft. Turn the battery master (BATT MASTR) switch ON and check the alternator ammeter for an indication of output. DO NOT ATTEMPT FLIGHT IF THERE IS NO INDICATION OF ALTERNATOR OUTPUT.

NOTE

For all normal operations using the PEP jumper cables, the battery master switch should be OFF. However, it is possible to use the ship's battery in parallel by turning the battery master switch ON. This will give longer cranking capabilities, but will not increase the amperage.

4.15d Engine Start With External Power Source (4.5d) (Continued)

CAUTION

Care should be exercised, because, if the ship's battery has been depleted, the external power supply can be reduced to the level of the ship's battery. This can be tested by turning the battery master switch ON momentarily while the starter is engaged. If cranking speed increases, the ship's battery is at a higher level than the external power supply.

When the engine is firing evenly, advance the throttle to 800 rpm. If oil pressure is not indicated within thirty seconds, stop the engine and determine the trouble. In cold weather it will take a few seconds longer to get an oil pressure indication. If the engine has failed to start, refer to the Lycoming Operating Handbook, Engine Troubles and Their Remedies.

Starter manufacturers recommend that cranking periods be limited to thirty seconds with a two minute rest between cranking periods. Longer cranking periods will shorten the life of the starter.

4.17 WARM-UP (4.5e)

Warm-up the engine at 800 to 1200 rpm for not more than two minutes in warm weather and four minutes in cold. Avoid prolonged idling at low rpm, as this practice may result in fouled spark plugs.

Takeoff may be made as soon as the ground check is completed, provided that the throttle may be opened fully without backfiring or skipping, and without a reduction in engine oil pressure.

Do not operate the engine at high rpm when running up or taxiing over ground containing loose stones, gravel or any loose material that may cause damage to the propeller blades.

4.19 TAXIING (4.5f)

Before ground personnel attempt to taxi the airplane, they should be instructed and approved by a qualified person authorized by the owner. Ascertain that the propeller back blast and taxi areas are clear.

4.19 TAXIING (4.5f) (Continued)

Power should be applied slowly to start the taxi roll. Taxi a few feet forward and apply the brakes to determine their effectiveness. While taxiing, make slight turns to ascertain the effectiveness of the steering.

Observe wing clearances when taxiing near buildings or other stationary objects. If possible, station an observer outside the airplane.

Avoid holes and ruts when taxiing over uneven ground.

Do not operate the engine at high rpm when running up or taxiing over ground containing loose stones, gravel or any loose material that may cause damage to the propeller blades.

4.21 GROUND CHECK (4.5g)

Set the parking brake and advance the throttle to 2000 rpm for checking the magnetos. Drop off on either magneto should not exceed 175 rpm and the difference between the magnetos should not exceed 50 rpm. Operation on one magneto should not exceed 10 seconds.

Check the vacuum gauge; the indicator should read 4.8 to 5.1 in. Hg at 2000 rpm.

Check the annunciator panel lights with the press-to-test button. Also check the air conditioner.

Carburetor heat should also be checked prior to takeoff to be sure the control is operating properly and to purge any ice which may have formed during taxiing. Avoid prolonged ground operation with carburetor heat ON as the air is unfiltered.

The electric fuel pump should be turned OFF after starting or during warm-up to make sure that the engine driven pump is operating. Check both oil temperature and oil pressure. The temperature may be low for some time if the engine is being run for the first time of the day. The engine is warm enough for takeoff when the throttle can be opened without the engine faltering.

4.23 BEFORE TAKEOFF (4.5h)

All aspects of each particular takeoff should be considered prior to executing the takeoff procedure.

Ensure that the battery master and alternator switches are ON. Check and set all of the flight instruments as required. Check the fuel selector to make sure it is on the proper tank (fullest). Turn ON the electric fuel pump to prevent loss of power should the engine driven pump fail during takeoff, and check the engine gauges. The carburetor heat should be in the OFF position. Check that all seat backs are erect.

NOTE

The mixture should be set FULL RICH, but a minimum amount of leaning is permitted for smooth engine operation when taking off at high elevation.

The mixture should be set, and the primer should be checked to ensure that it is locked.

NOTE

The inertia reel type shoulder harness should be given a pull test to check its locking restraint feature.

NOTE

If the fixed shoulder harness (non-inertia reel type) are installed for the aft seat occupants they should be adjusted to provide adequate restraint.

Pull test the locking restraint feature of the shoulder harness inertia reel. Fasten seat belts snugly around empty seats.

Exercise and set the flaps and trim. Ensure proper flight control movement and response. The door should be properly secured and latched. On air conditioned models, the air conditioner must be OFF to ensure normal takeoff performance.

4.25 TAKEOFF (See charts in Section 5) (4.5i)

Takeoffs are normally made with flaps up; however, for short field takeoffs and for takeoffs under difficult conditions, such as deep grass or a soft surface, total distances can be reduced appreciably by lowering the flaps to 25°

4.25a Normal (4.5i)

The normal takeoff technique is conventional. The trim should be set slightly aft of neutral, with the exact setting determined by the loading of the airplane. Allow the airplane to accelerate to 45 to 55 KIAS, then ease back on the control wheel to rotate to climb attitude. Premature raising of the nose or raising it to an excessive angle will result in a delayed takeoff. After takeoff, let the airplane accelerate to the desired climb speed by lowering the nose slightly.

4.25b 0° Flaps Takeoff Performance (4.5i)

A short field takeoff is accomplished without flaps by applying full power before brake release; lift off at 40-50 KIAS (depending on weight) and accelerate to and maintain 44-55 KIAS (depending on weight) past obstacle and climb out at 79 KIAS.

4.25c 25° Flaps Takeoff Performance (4.5i)

A short field takeoff with an obstacle clearance is accomplished by first lowering the flaps to 25°. Apply full power before brake release and accelerate to 40-50 KIAS (depending on weight) and rotate. Accelerate to and maintain 44-55 KIAS (depending on weight) until obstacle clearance is attained. After the obstacle has been cleared, accelerate to 79 KIAS and then slowly retract the flaps.

4.25d Soft Field, Obstacle Clearance (4.5i)

Takeoff from a soft field with an obstacle clearance requires the use of 25° flaps. Accelerate the airplane and lift the nose gear off as soon as possible and lift off at the lowest possible airspeed. Accelerate just above the ground to 52 KIAS to climb past obstacle clearance height. Continue climbing while accelerating to the best rate of climb speed, 79 KIAS and slowly retract the flaps.

4.25e Soft Field, No Obstacle (4.5i)

For a soft field takeoff without an obstacle to clear, extend the flaps 25°, accelerate the airplane and lift the nose gear off as soon as possible. Lift off at the lowest possible airspeed. Accelerate just above the ground to the best rate of climb speed, 79 KIAS, and retract the flaps while climbing out.

4.27 CLIMB (4.5j)

The best rate of climb at gross weight will be obtained at 79 KIAS. The best angle of climb may be obtained at 63 KIAS. At lighter than gross weight these speeds are reduced somewhat. For climbing en route, a speed of 87 KIAS is recommended. This will produce better forward speed and increased visibility over the nose during the climb.

When reaching the desired altitude, the electric fuel pump may be turned off.

4.29 CRUISE (4.5k)

The cruising efficiency and speed is determined by many factors, including power setting, altitude, temperature, loading and equipment installed in the airplane.

The normal cruising power is 55% to 75% of the rated horsepower of the engine. Airspeeds which may be obtained at various altitudes and power settings can be determined from the performance graphs provided by Section 5.

Use of the mixture control in cruising flight significantly reduces fuel consumption while reducing lead deposits when alternate fuels are used. The mixture should be full rich when operating above 75% power, and leaned during cruising operation when 75% power or less is being used.

To lean the mixture for best power cruise performance place the mixture control full forward and set the throttle approximately 35 rpm below the desired cruise power setting and lean the mixture to peak rpm. Adjust the throttle, if necessary, for final rpm setting.

4.29 CRUISE (4.5k) (Continued)

CAUTION

Prolonged operation with a lean mixture, at more than 75% engine power, can result in engine damage. When leaning to establish best economy cruise mixture below 6,000 feet, care must be taken not to remain in the power range above 75% more than 15 seconds. Above 6,000 feet, the engine is incapable of producing more than 75% power.

A simplified leaning procedure has been developed to obtain the best engine efficiency, while providing the best fuel economy and maximum miles per gallon, for a given power setting. Taking care not to exceed engine speed limitations, set the throttle and mixture controls full forward. Now, begin to lean the mixture. At first the rpm will increase slightly but, as leaning is continued, the rpm will decrease. Continue leaning until the desired cruise engine rpm is established.

Always turn the electric fuel pump ON before switching tanks, and leave it ON for a short period thereafter. To keep the airplane in best lateral trim during cruising flight, use fuel alternately from each tank. It is recommended that one tank be used for one hour after takeoff, then the other tank be used for two hours; then return to the first tank, which will have approximately one and one half hours of fuel remaining if the tanks were full at takeoff. The second tank will contain approximately one half hour of fuel. Do not run tanks completely dry in flight. The electric fuel pump should normally be OFF, so that any malfunction of the engine driven fuel pump is immediately apparent. If signs of fuel starvation should occur at any time during flight, suspect fuel exhaustion. Immediately position the fuel selector to the other tank, and switch the electric fuel pump ON.

4.31 DESCENT (4.5m)

4.31a Normal Descent (4.5m)

To achieve the performance on Figure 5-31, a power on descent must be used. The throttle should be set for 2500 rpm, mixture full rich and maintain an airspeed of 126 KIAS. If carburetor ice is encountered apply full carburetor heat.

4.31b Power Off Descent (4.5m)

If a prolonged power off descent is to be made, and icing conditions are suspected, apply full carburetor heat prior to power reduction. Throttle should be retarded and mixture control leaned as required. Power response should be verified approximately every 30 seconds by partially opening and then closing the throttle (clearing the engine). When leveling off, enrichen mixture, set power as required and select carburetor heat off unless carburetor icing conditions are suspected.

4.33 APPROACH AND LANDING (See charts in Section 5) (4.5n)

Check to ensure the fuel selector is on the proper (fullest) tank and that the seat backs are erect. The seat belts and shoulder harnesses should be fastened and the inertia reel checked.

NOTE

If the fixed shoulder harness (non-inertia reel type) is installed, it must be connected to the seat belt and adjusted to allow proper accessibility to all controls including fuel selector, flaps, trim, etc, while maintaining adequate restraint for the occupant.

NOTE

If the inertia reel type shoulder harness is installed, a pull test of its locking restraint feature should be performed.

Turn the electric fuel pump ON and turn the air conditioner OFF. The mixture should be set in the full RICH position.

The airplane should be trimmed to an initial approach speed of 70 KIAS, and a final approach speed of 63 KIAS with flaps extended to 40°. If desired, the flaps can be lowered at speeds up to 103 KIAS.

The mixture control should be kept in full RICH position to ensure maximum acceleration if it should be necessary to open the throttle again. Carburetor heat should not be applied unless there is an indication of carburetor icing, since the use of carburetor heat causes a reduction in power which may be critical in case of a go-around. Full throttle operation with carburetor heat on can cause detonation.

4.33 APPROACH AND LANDING (See charts in Section 5) (4.5n) (Continued)

The amount of flap used during landings and the speed of the aircraft at contact with the runway should be varied according to the landing surface and conditions of wind and airplane loading. It is generally good practice to contact the ground at the minimum possible safe speed consistent with existing conditions.

Normally, the best technique for short and slow landings is to use full flap and enough power to maintain the desired airspeed and approach flight path. Mixture should be full RICH, fuel on the fullest tank, and electric fuel pump ON. Reduce the speed during the flareout and contact the ground close to the stalling speed. After ground contact hold the nose wheel off as long as possible. As the airplane slows down, gently lower the nose and apply the brakes. Braking is most effective when flaps are raised and back pressure is applied to the control wheel, putting most of the aircraft weight on the main wheels. In high wind conditions, particularly in strong crosswinds, it may be desirable to approach the ground at higher than normal speeds with partial or no flaps.

4.35 STOPPING ENGINE (4.5o)

The flaps should be raised at the pilot's discretion. Turn OFF the electric fuel pump and all electrical switches. The air conditioner and radios should be turned OFF. Stop the engine by pulling the mixture control back to idle cut-off. The throttle should be left full aft to avoid engine vibration while stopping. After the engine stops, turn the magneto, battery master, and alternator switches OFF, and reset the trim.

NOTE

When alternate fuels are used, the engine should be run up to 1200 rpm for one minute prior to shutdown to clean out any unburned fuel.

NOTE

The flaps must be placed in the UP position for the flap step to support weight. Passengers should be cautioned accordingly.

4.37 MOORING (4.5p)

If necessary to move the airplane on the ground, use a nose wheel tow bar. The aileron and stabilator controls should be secured by looping the safety belt through the control wheel and pulling it snug. The flaps are locked when in the UP position and should be left retracted.

Tie downs can be secured to rings provided under each wing and to the tail skid. The rudder is held in position by its connections to the nose wheel steering and normally does not have to be secured.

4.39 STALLS

The stall characteristics are conventional. An approaching stall is indicated by a stall warning horn which is activated between five and ten KTS above stall speed. Mild airframe buffeting and gentle pitching may also precede the stall.

The gross weight stalling speed with power off and full flaps is 44 KIAS. With the flaps up this speed is increased. Loss of altitude during stalls varies from 100 to 275 feet, depending on configuration and power.

NOTE

The stall warning system is inoperative with the master switch OFF.

During preflight, the stall warning system should be checked by turning the master switch ON, lifting the detector and checking to determine if the horn is actuated. The master switch should be returned to the OFF position after the check is complete.

4.41 TURBULENT AIR OPERATION

In keeping with good operating practice used in all aircraft, it is recommended that when turbulent air is encountered or expected, the airspeed be reduced to maneuvering speed to reduce the structural loads caused by gusts and to allow for inadvertent speed build-ups which may occur as a result of the turbulence or of distractions caused by the conditions. (See Subsection 2.3.)

4.43 WEIGHT AND BALANCE

It is the responsibility of the owner and pilot to determine that the airplane remains within the allowable weight vs. center of gravity envelope while in flight.

For weight and balance data, refer to Section 6 (Weight and Balance).

4.45 NOISE LEVEL

The noise level of this aircraft is 72.0 dB(A).

No determination has been made by the Federal Aviation Administration that the noise levels of this airplane are or should be acceptable or unacceptable for operation at, into, or out of, any airport.

The above statement notwithstanding, the noise level stated above has been verified by and approved by the Federal Aviation Administration in noise level test flights conducted in accordance with FAR 36, Noise Standards - Aircraft Type and Airworthiness Certification. This aircraft model is in compliance with all FAR 36 noise standards applicable to this type.

THIS PAGE INTENTIONALLY LEFT BLANK

**TABLE OF CONTENTS
SECTION 5
PERFORMANCE**

Paragraph No.		Page No.
5.1	General	5-1
5.3	Introduction - Performance and Flight Planning	5-1
5.5	Flight Planning Example	5-3
5.7	Performance Graphs	5-9
	List of Figures	5-9

Handwritten text, likely bleed-through from the reverse side of the page. The text is extremely faint and illegible due to the quality of the scan and the nature of the bleed-through.

SECTION 5
PERFORMANCE

5.1 GENERAL

All FAA required, as well as complementary performance information applicable to the Cadet, is provided by this section.

Performance information associated with optional systems and equipment that require handbook supplements is provided in Section 9, Supplements.

5.3 INTRODUCTION - PERFORMANCE AND FLIGHT PLANNING

The performance information presented in this section is based on measured Flight Test Data corrected to I.C.A.O. standard day conditions and analytically expanded for the various parameters of weight, altitude, temperature, etc.

The performance charts are unfactored and do not make any allowance for varying degrees of pilot proficiency or mechanical deterioration of the aircraft. This performance, however, can be duplicated by following the stated procedures in a properly maintained airplane.

Effects of conditions not considered on the charts must be evaluated by the pilot, such as a soft or grass runway surface on takeoff and landing performance, or winds aloft on cruise and range performance. Endurance can be grossly affected by improper leaning procedures, and inflight fuel flow and quantity checks are recommended.

REMEMBER! To get chart performance, follow the chart procedures.

**SECTION 5
PERFORMANCE**

**PIPER AIRCRAFT CORPORATION
PA-28-161, CADET**

The information provided by paragraph 5.5 (Flight Planning Example) outlines a detailed flight plan using the performance charts in this section. Each chart includes its own example to show how it is used.

WARNING

Performance information derived by extrapolation beyond the limits shown on the charts should not be used for flight planning purposes.

5.5 FLIGHT PLANNING EXAMPLE

(a) Aircraft Loading

The first step in planning a flight is to calculate the airplane weight and center of gravity by utilizing the information provided by Section 6 (Weight and Balance) of this handbook.

The basic empty weight for the airplane as licensed at the factory has been entered in Figure 6-5. If any alterations to the airplane have been made affecting weight and balance, reference to the aircraft logbook and Weight and Balance Record (Figure 6-7) should be made to determine the current basic empty weight of the airplane.

Make use of the Weight and Balance Loading Form (Figure 6-11) and the C.G. Range and Weight graph (Figure 6-15) to determine the total weight of the airplane and the center of gravity position.

After proper utilization of the information provided, the following weights apply to the flight planning example.

The landing weight cannot be determined until the weight of the fuel to be used has been established [refer to item (g)(1)].

(1) Basic Empty Weight	1505 lbs.
(2) Occupants (3 x 170 Lbs)	510 lbs.
(3) Baggage and Cargo	50 lbs.
(4) Fuel (6 lb/gal x 44.5)	267 lbs.
(5) Engine Start, Taxi, and Runup	-7 lbs.
(6) Takeoff Weight	2325 lbs.
(7) Landing Weight	
(a)(6) minus (g)(1), (2325 lbs.	
minus 142.5)	2182.5 lbs.

The takeoff weight does not exceed the maximum of 2325 lbs., and the weight and balance calculations have determined that the c.g. position is within the approved limits.

(b) Takeoff and Landing

Now that the aircraft loading has been determined, all aspects of the takeoff and landing must be considered.

All of the existing conditions at the departure and destination airport must be acquired, evaluated and maintained throughout the flight.

Apply the departure airport conditions and takeoff weight to the appropriate Takeoff Performance graph (Figures 5-7 and 5-9 or 5-11 and 5-13) to determine the length of runway necessary for the takeoff and/or the barrier distance.

The landing distance calculations are performed in the same manner using the existing conditions at the destination airport and, when established, the landing weight.

The conditions and calculations for the example flight are listed below. The takeoff and landing distances required for the example flight have fallen well below the available runway lengths.

	Departure Airport	Destination Airport
(1) Pressure Altitude	500 ft.	2500 ft.
(2) Temperature	38° C	24° C
(3) Wind Component	15 kts	0 kts
	(Headwind)	
(4) Runway Length Available	4800 ft.	7600 ft.
(5) Runway Required	2100 ft.*	1190 ft.**

NOTE

The remainder of the performance charts used in this flight planning example assume a no wind condition. The effect of winds aloft must be considered by the pilot when computing climb, cruise and descent performance.

*reference Figure 5-9

**reference Figure 5-35

(c) Climb

The next step in the flight plan is to determine the necessary climb segment components.

The desired cruise pressure altitude and corresponding cruise outside air temperature values are the first variables to be considered in determining the climb components from the Fuel, Time and Distance to Climb graph (Figure 5-19). After the fuel, time and distance for the cruise pressure altitude and outside air temperature values have been established, apply the existing conditions at the departure field to graph (Figure 5-19). Now, subtract the values obtained from the graph for the field of departure conditions from those for the cruise pressure altitude.

The remaining values are the true fuel, time and distance components for the climb segment of the flight plan corrected for field pressure altitude and temperature.

The following values were determined from the above instructions in the flight planning example.

(1) Cruise Pressure Altitude	5000 ft.
(2) Cruise OAT	16°C
(3) Fuel to Climb (2 gal. minus 0.25 gal.)	1.75 gal.*
(4) Time to Climb (12.0 min. minus 1.0 min.)	11.0 min.*
(5) Distance to Climb (14.5 miles minus 1.5 miles)	13.0 miles*

(d) Descent

The descent data will be determined prior to the cruise data to provide the descent distance for establishing the total cruise distance.

Utilizing the cruise pressure altitude and OAT, determine the basic fuel, time and distance for descent (Figure 5-31). These figures must be adjusted for the field pressure altitude and temperature at the destination airport. To find the necessary adjustment values, use the existing pressure altitude and temperature conditions at the destination airport as variables to find the fuel, time and distance

*reference Figure 5-19

values from the graph (Figure 5-31). Now, subtract the values obtained from the field conditions from the values obtained from the cruise conditions to find the true fuel, time and distance values needed for the flight plan.

The values obtained by proper utilization of the graphs for the descent segment of the example are shown below.

(1) Fuel to Descend (1.0 gal. minus 0.5 gal.)	0.5 gal.*
(2) Time to Descend (6.5 min. minus 3.5 min.)	3.0 min.*
(3) Distance to Descend (13.5 miles minus 7.0 miles)	6.5 miles*

(e) Cruise

Using the total distance to be traveled during the flight, subtract the previously calculated distance to climb and distance to descend to establish the total cruise distance. Refer to the appropriate Avco Lycoming Operator's Manual when selecting the cruise power setting. The established pressure altitude and temperature values and the selected cruise power should now be utilized to determine the true airspeed from the Cruise Performance graph (Figure 5-21 or 5-23).

Calculate the cruise fuel consumption for the cruise power setting from the information provided by the Avco Lycoming Operator's Manual.

The cruise time is found by dividing the cruise distance by the cruise speed and the cruise fuel is found by multiplying the cruise fuel consumption by the cruise time.

The cruise calculations established for the cruise segment of the flight planning example are as follows:

(1) Total Distance	300 miles
(2) Cruise Distance (c)1 minus (c)5 minus (d)3. (300 minus 13.0 miles minus 6.5 miles)	280.5 miles

*reference Figure 5-31

- | | |
|--|-------------------------------|
| (3) Cruise Power Best Economy Mixture | 75% rated power
(2625 rpm) |
| (4) Cruise Speed | 111 kts TAS* |
| (5) Cruise Fuel Consumption | 8.5 gph |
| (6) Cruise Time
(e)(2) divided by (e)(4), (280.5 miles divided by 111 kts) | 2.53 hrs. |
| (7) Cruise Fuel
(e)(5) multiplied by (e)(6), (8.5 gph multiplied by 2.53 hrs) | 21.5 gal. |

(f) Total Flight Time

The total flight time is determined by adding the time to climb, the time to descend and the cruise time. Remember! The time values taken from the climb and descent graphs are in minutes and must be converted to hours before adding them to the cruise time.

The following flight time is required for this flight planning example:

- | | |
|---|-----------|
| (1) Total Flight Time
(c)(4) plus (d)(2) plus (e)(6),
(0.18 hrs. plus 0.05 hrs. plus 2.53 hrs.) | 2.76 hrs. |
|---|-----------|

(g) Total Fuel Required

Determine the total fuel required by adding the fuel to climb, the fuel to descend and the cruise fuel. When the total fuel (in gallons) is determined, multiply this value by 6 lb/gal. to determine the total fuel weight used for the flight.

The total fuel calculations for the example flight plan are shown below.

- | | |
|--|--------------------------|
| (1) Total Fuel Required
(c)(3) plus (d)(1) plus (e)(7),
(1.75 gal. plus 0.5 gal. plus 21.5 gal.)
(23.75 gal. multiplied by 6 lb/gal.) | 23.75 gal.
142.5 lbs. |
|--|--------------------------|

*reference Figure 5-23

THIS PAGE INTENTIONALLY LEFT BLANK

5.7 PERFORMANCE GRAPHS

LIST OF FIGURES

Figure No.		Page No.
5-1	Temperature Conversion.....	5-11
5-3	Airspeed System Calibration	5-12
5-5	Stall Speed	5-13
5-6	Wind Components	5-13b
5-7	0° Flaps Takeoff Ground Roll	5-14
5-9	0° Flaps Takeoff Performance.....	5-15
5-11	25° Flaps Takeoff Ground Roll	5-16
5-13	25° Flaps Takeoff Performance.....	5-17
5-15	Engine Performance	5-18
5-17	Climb Performance	5-19
5-19	Fuel, Time and Distance to Climb	5-20
5-21	Best Power Cruise Performance	5-21
5-23	Best Economy Cruise Performance	5-22
5-25	Best Power Mixture Range	5-23
5-27	Best Economy Mixture Range	5-24
5-29	Endurance	5-25
5-31	Fuel, Time and Distance to Descend	5-26
5-33	Glide Performance	5-27
5-35	Landing Distance	5-28

THIS PAGE INTENTIONALLY LEFT BLANK

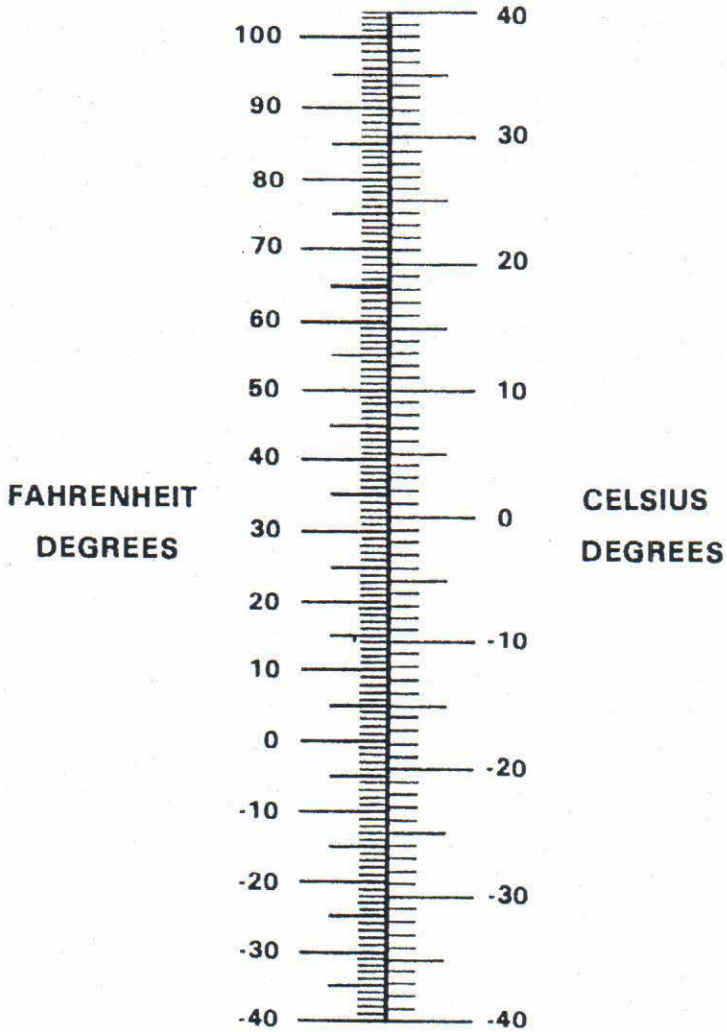

TEMPERATURE CONVERSION
Figure 5-1

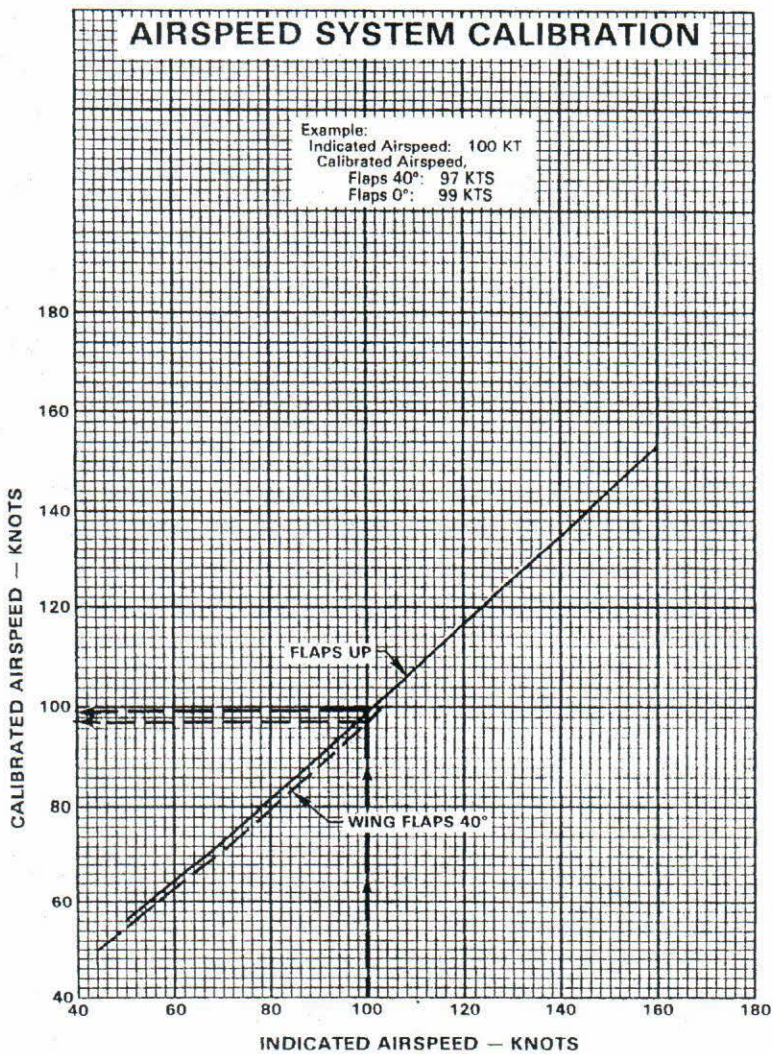

AIRSPEED SYSTEM CALIBRATION
Figure 5-3

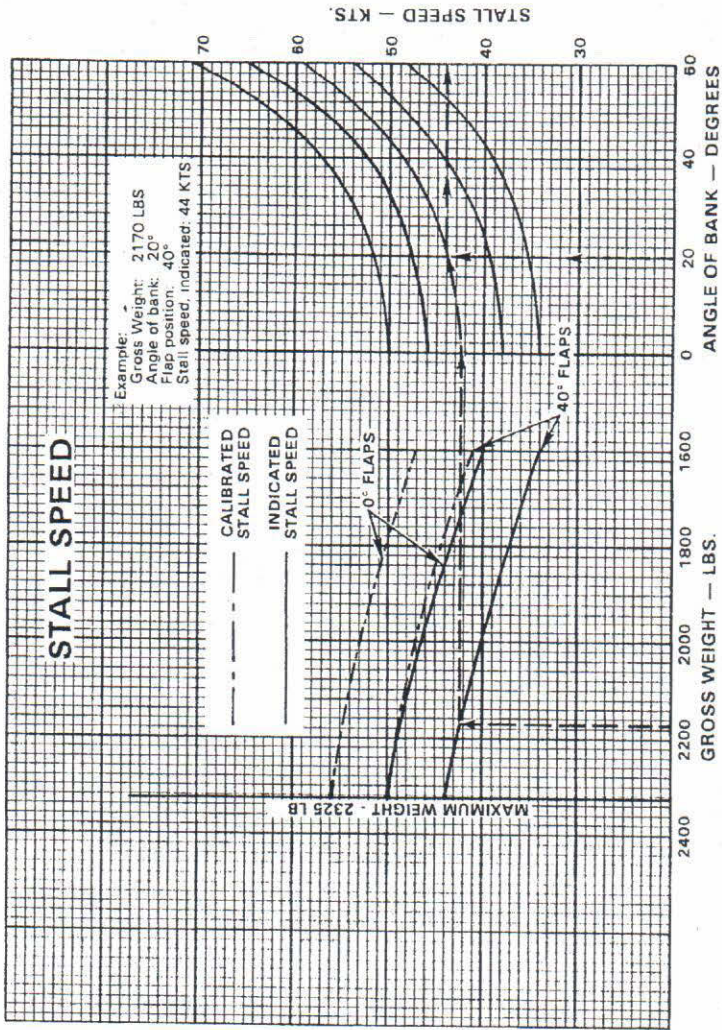

STALL SPEED
Figure 5-5

THIS PAGE INTENTIONALLY LEFT BLANK

WIND COMPONENTS

Example:
Wind velocity: 30 KT
Angle between flight path and wind: 30°
Headwind: 26 KT
Crosswind component: 15 KT

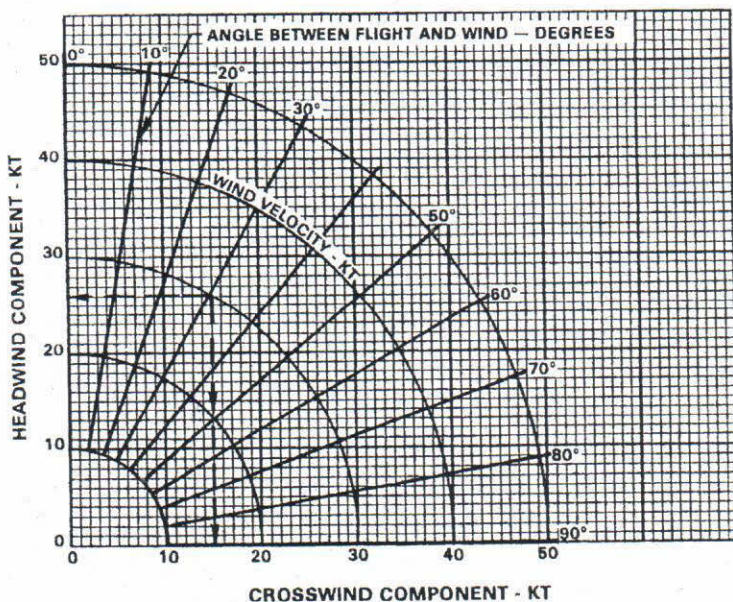

WIND COMPONENTS
Figure 5-6

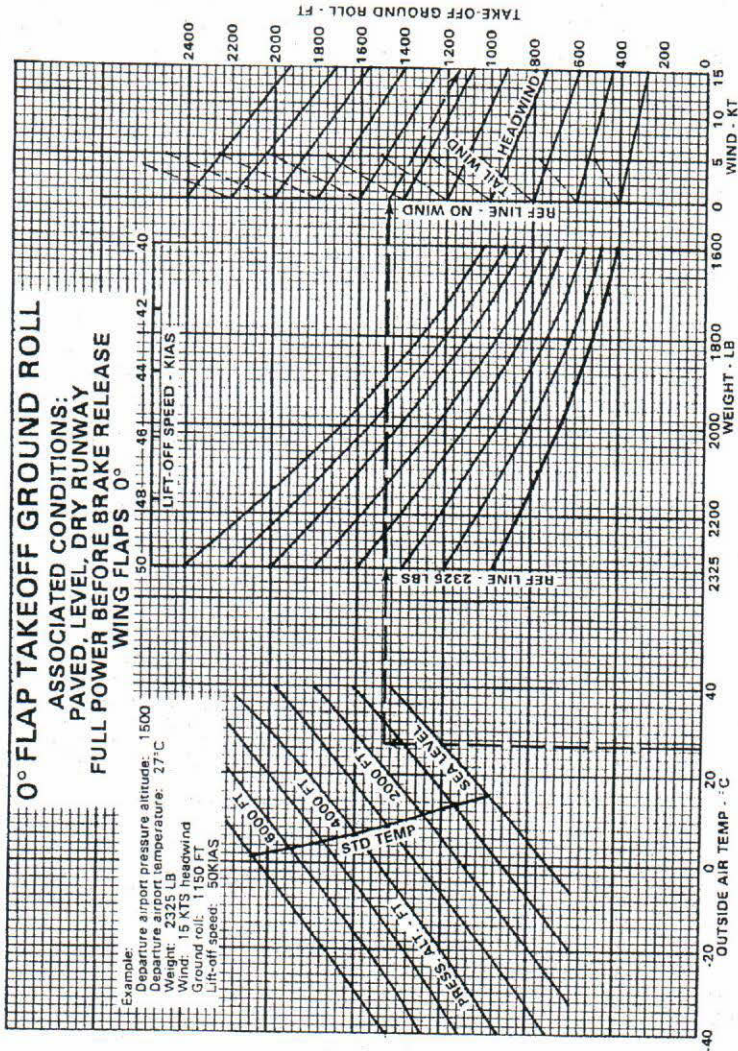

0° FLAPS TAKEOFF GROUND ROLL

Figure 5-7

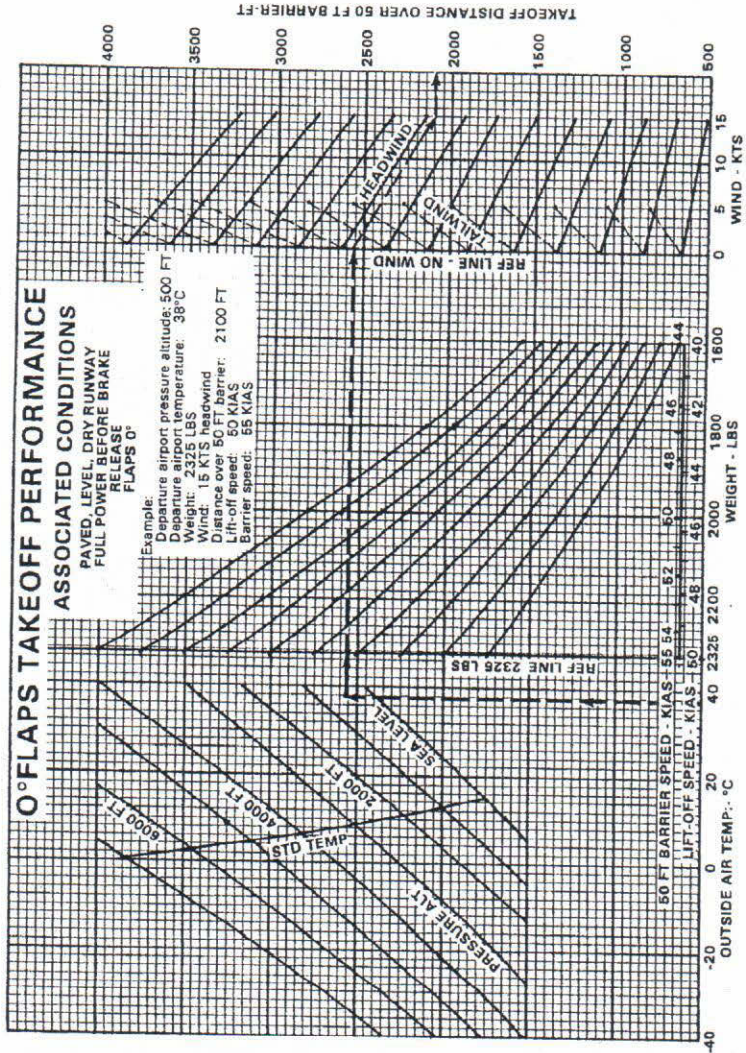

0° FLAPS TAKEOFF PERFORMANCE

Figure 5-9

ISSUED: SEPTEMBER 9, 1988
 REVISED: NOVEMBER 27, 1989

REPORT: VB-1360 |

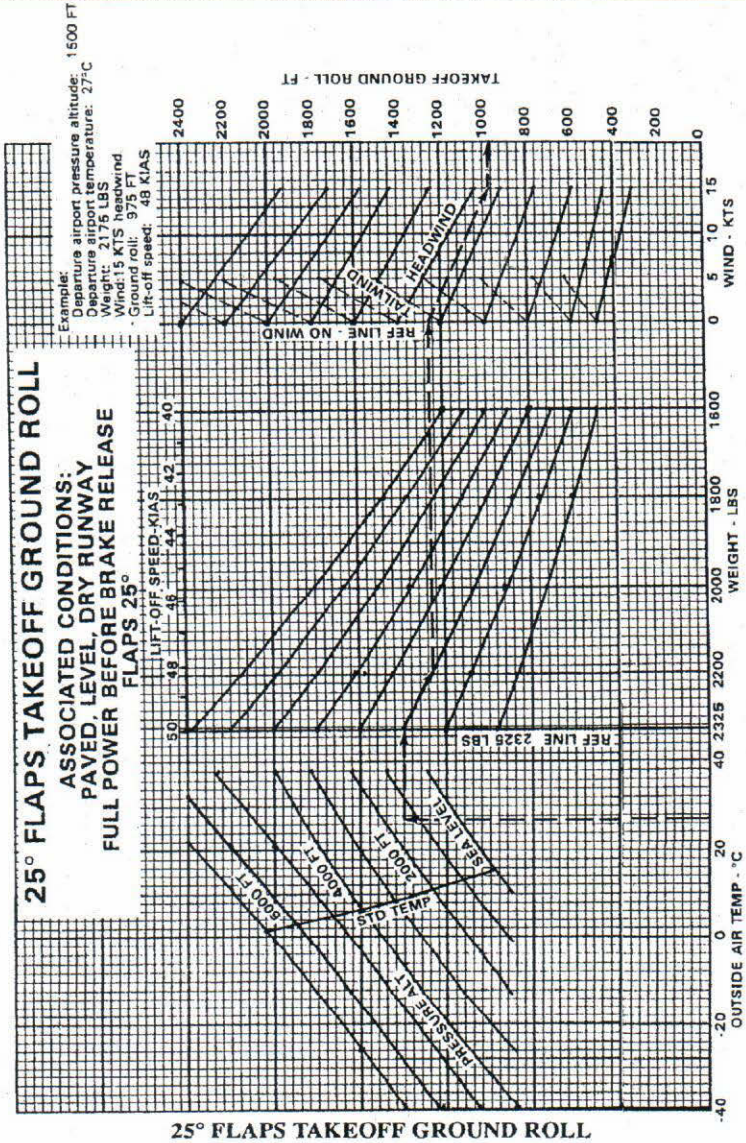
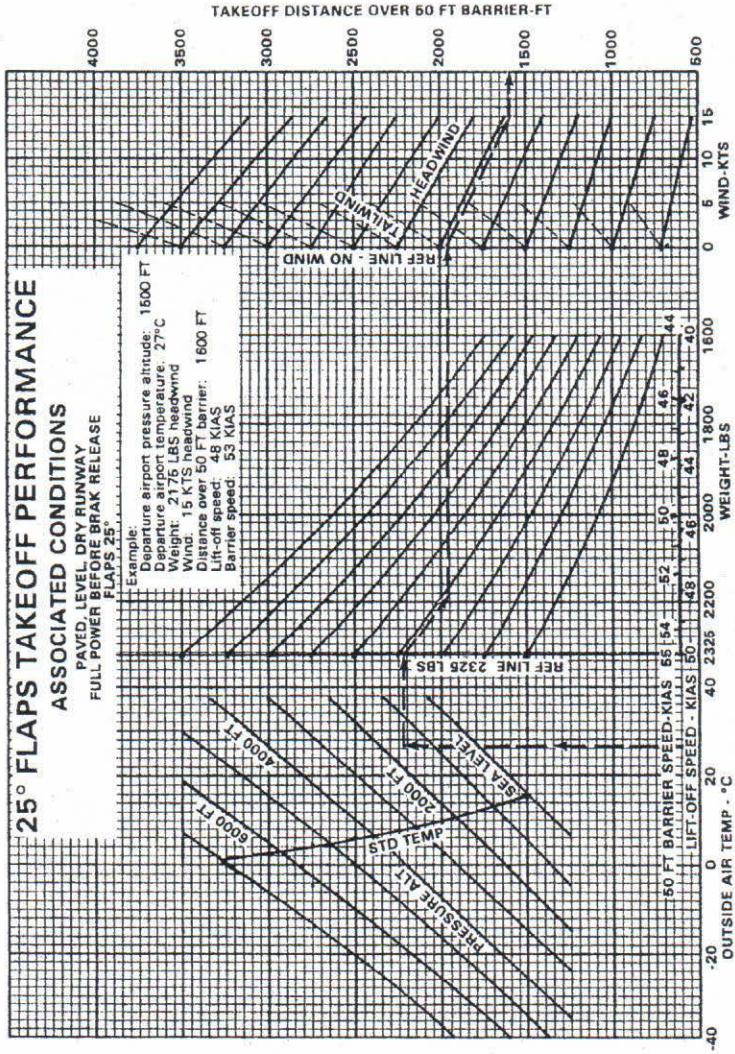
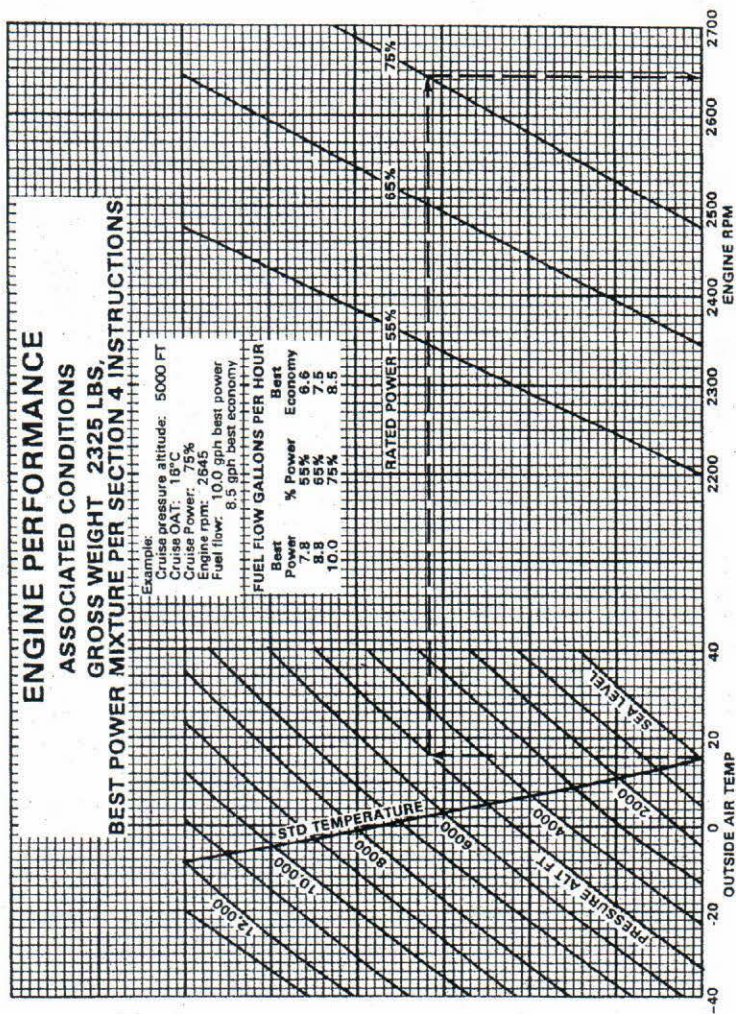

Figure 5-11



25° FLAPS TAKEOFF PERFORMANCE
Figure 5-13



ENGINE PERFORMANCE

Figure 5-15

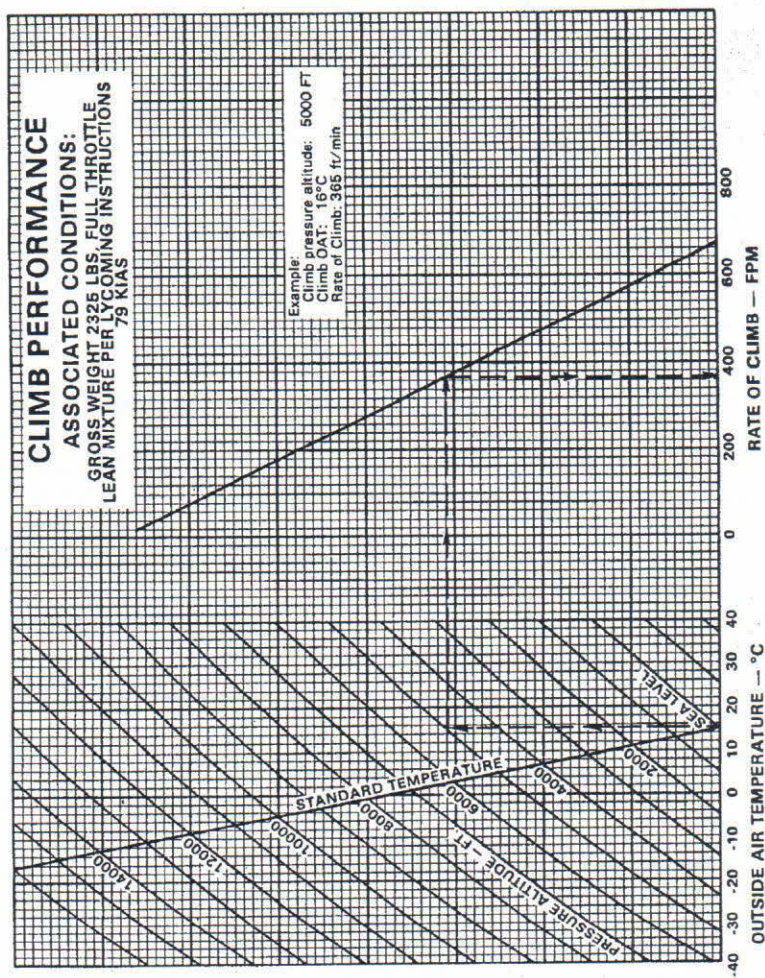

CLIMB PERFORMANCE
Figure 5-17

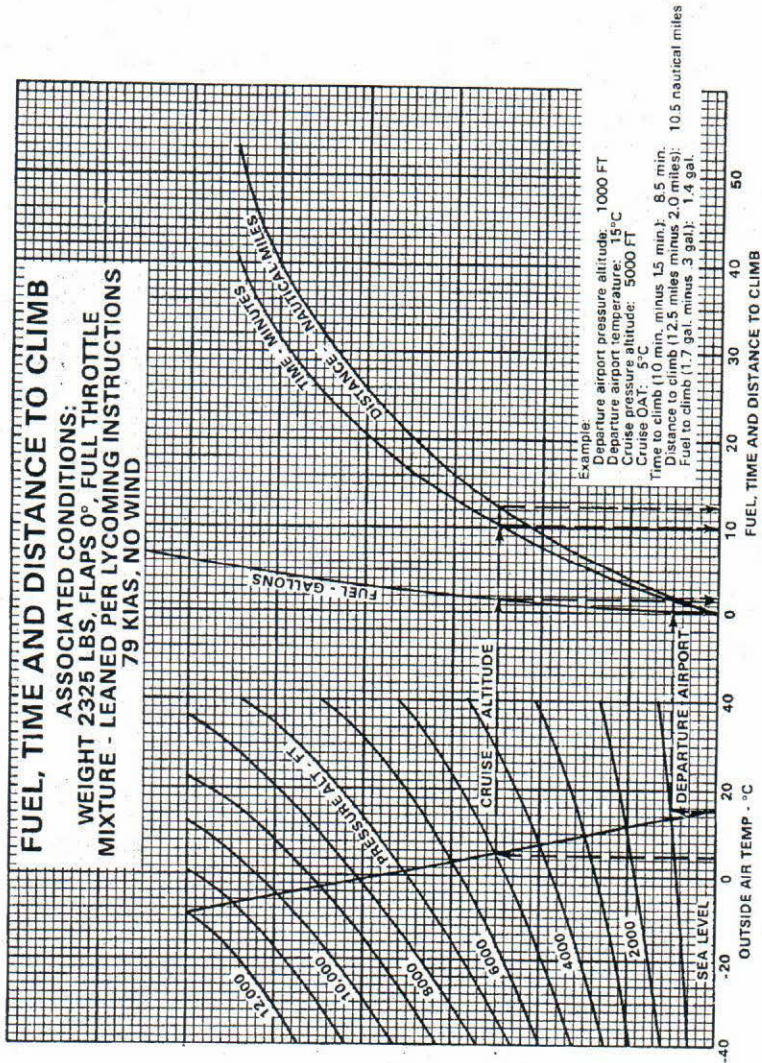

FUEL, TIME AND DISTANCE TO CLIMB

Figure 5-19

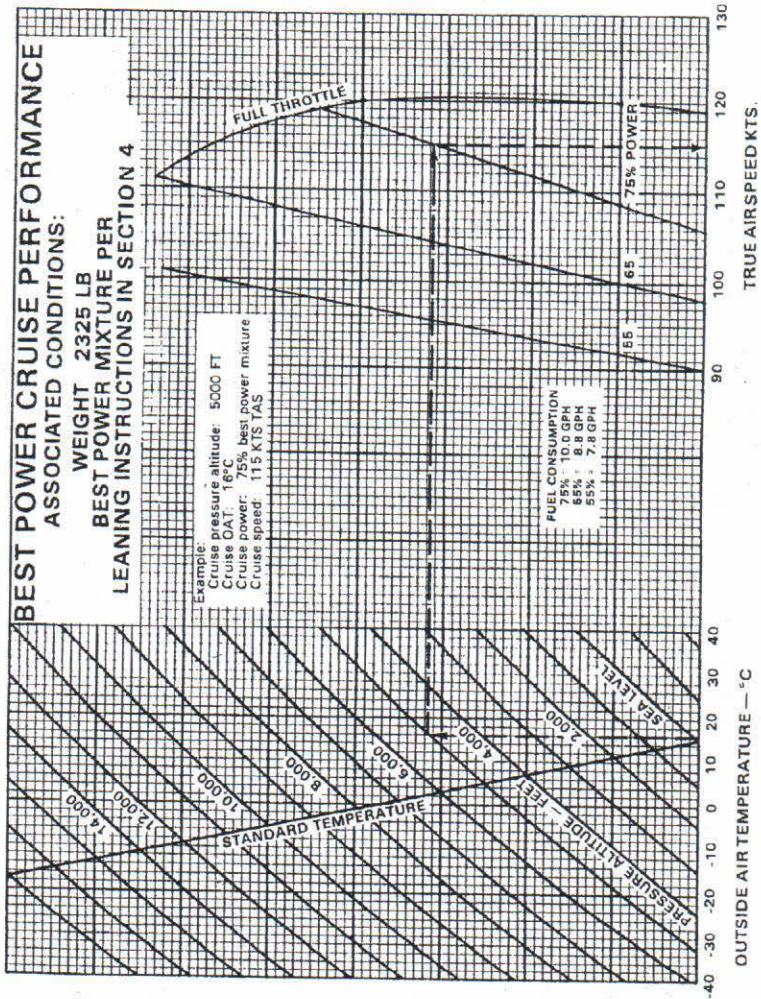

BEST POWER CRUISE PERFORMANCE
Figure 5-21

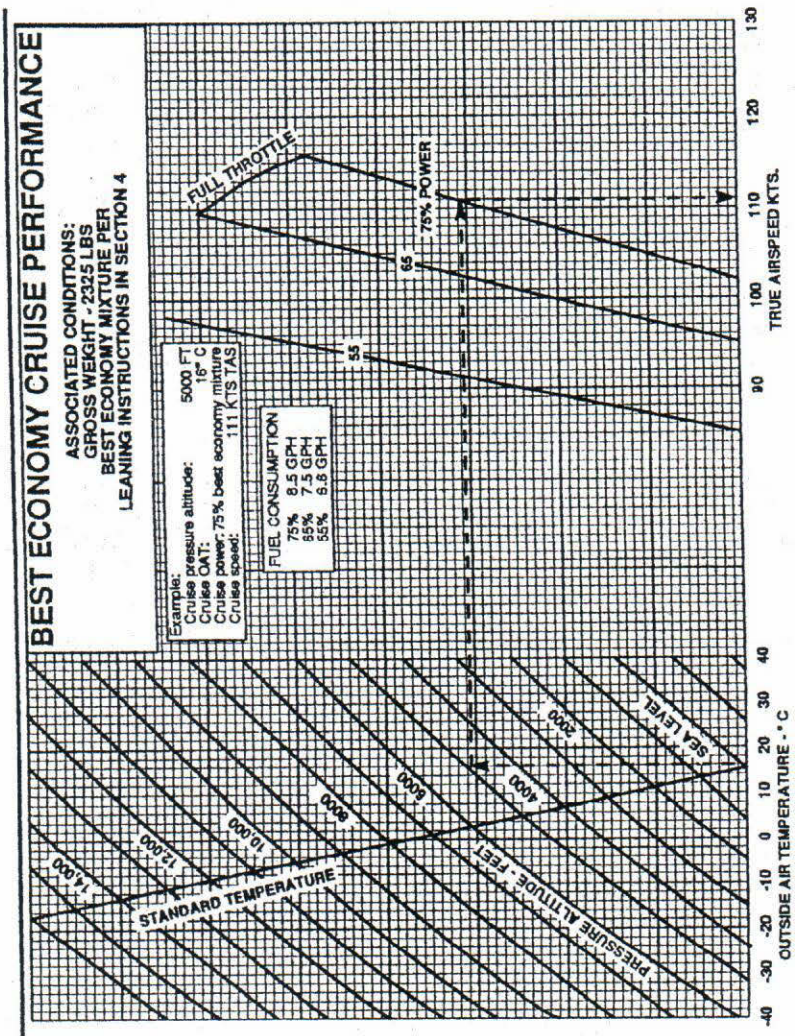

BEST ECONOMY CRUISE PERFORMANCE

Figure 5-23

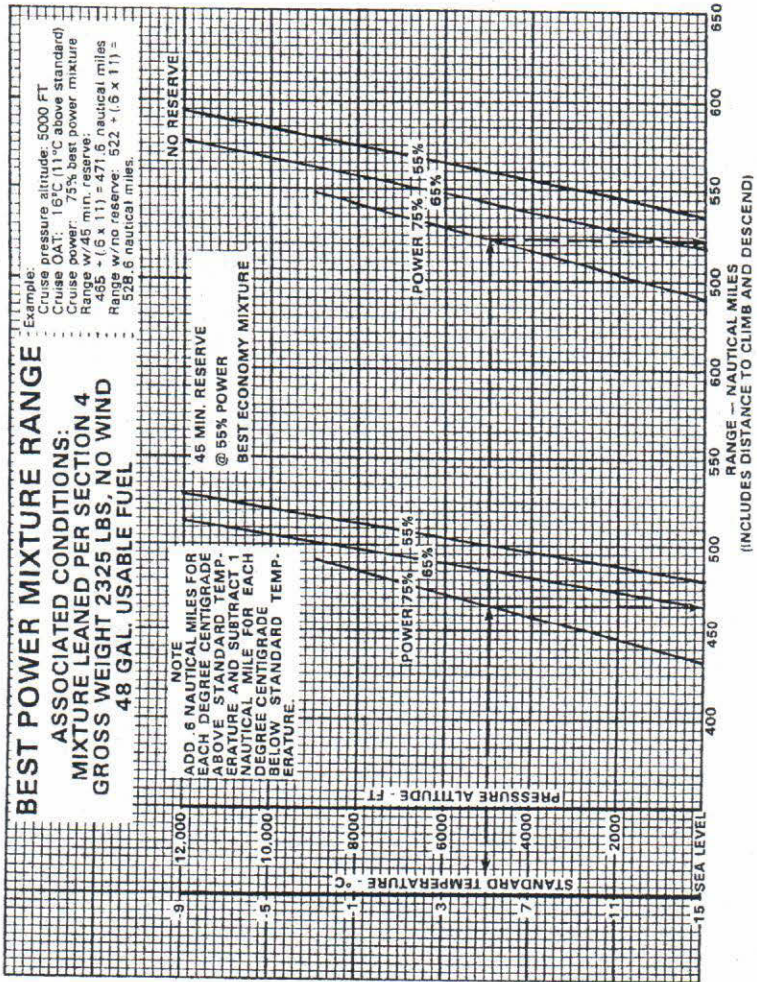

BEST POWER MIXTURE RANGE
 Figure 5-25

ISSUED: SEPTEMBER 9, 1988
 REVISED: DECEMBER 16, 1988

REPORT: VB-1360
 5-23

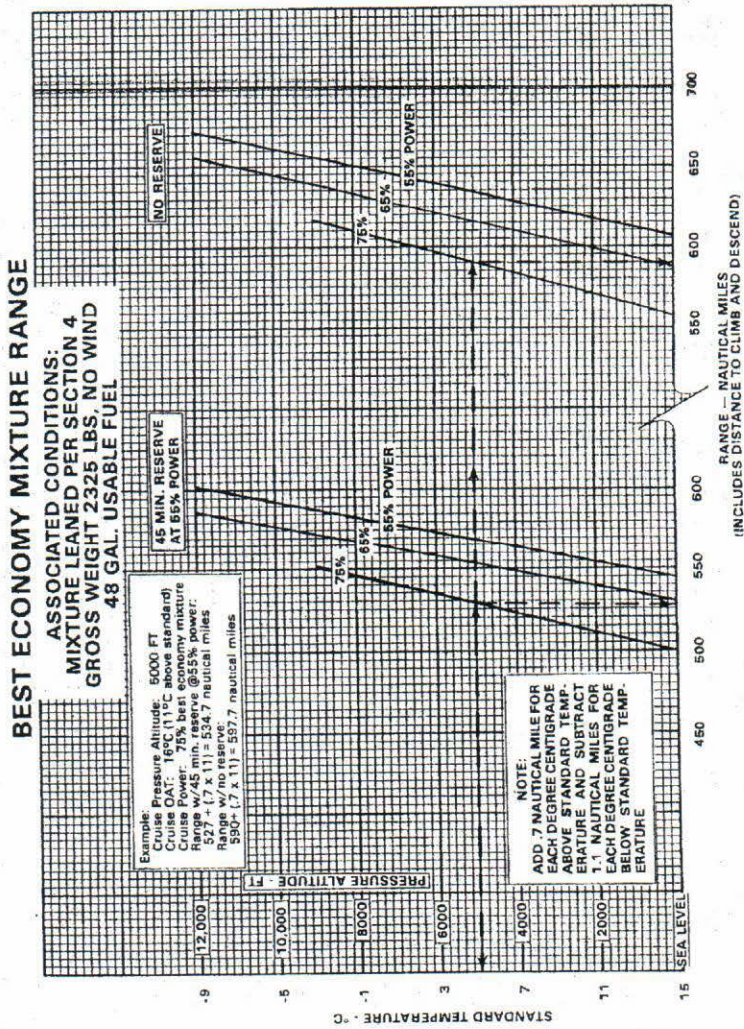

BEST ECONOMY MIXTURE RANGE

Figure 5-27

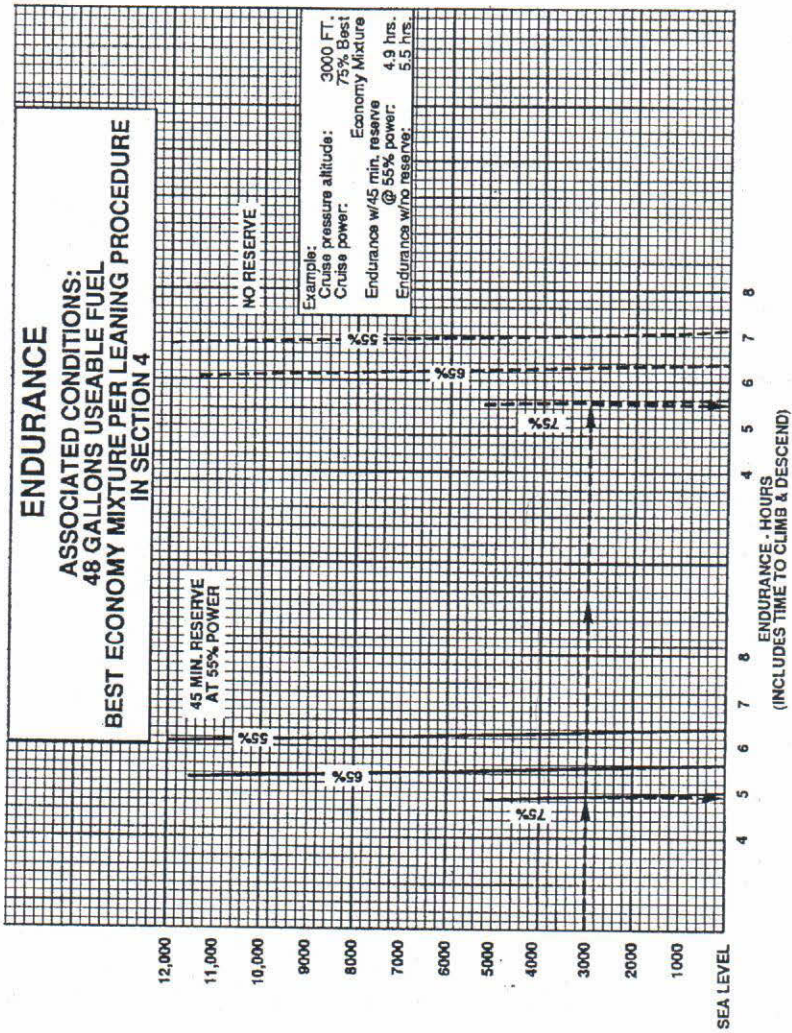

ENDURANCE
Figure 5-29

ISSUED: SEPTEMBER 9, 1988
REVISED: NOVEMBER 27, 1989

REPORT: VB-1360
5-25

**SECTION 5
PERFORMANCE**

**PIPER AIRCRAFT CORPORATION
PA-28-161, CADET**

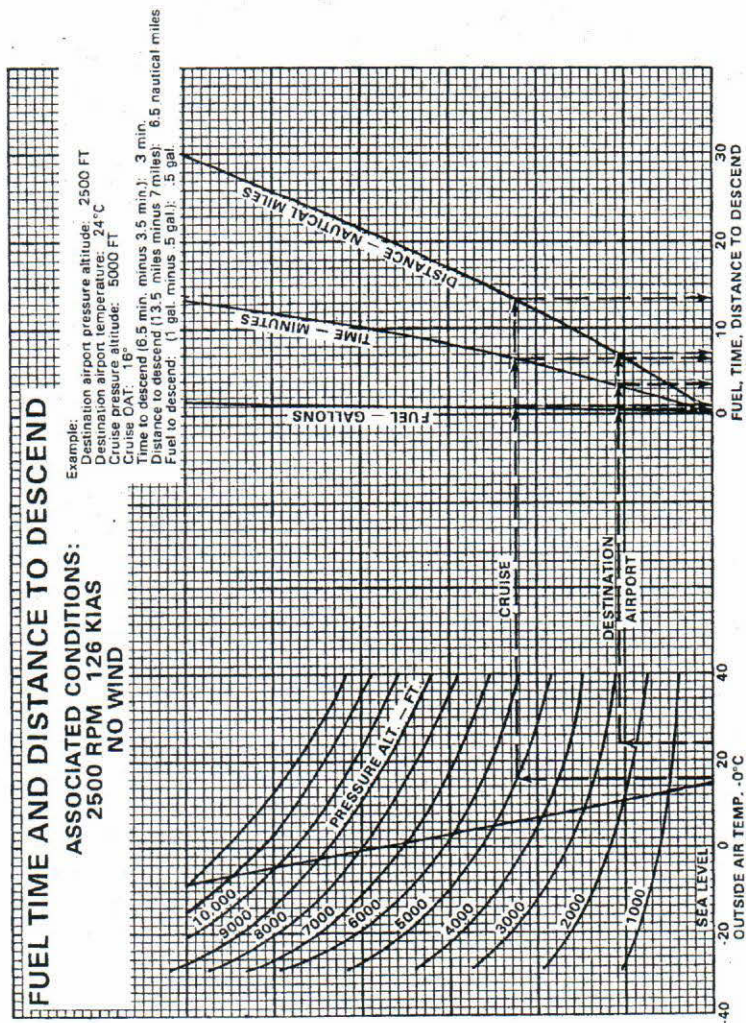

FUEL, TIME AND DISTANCE TO DESCEND
Figure 5-31

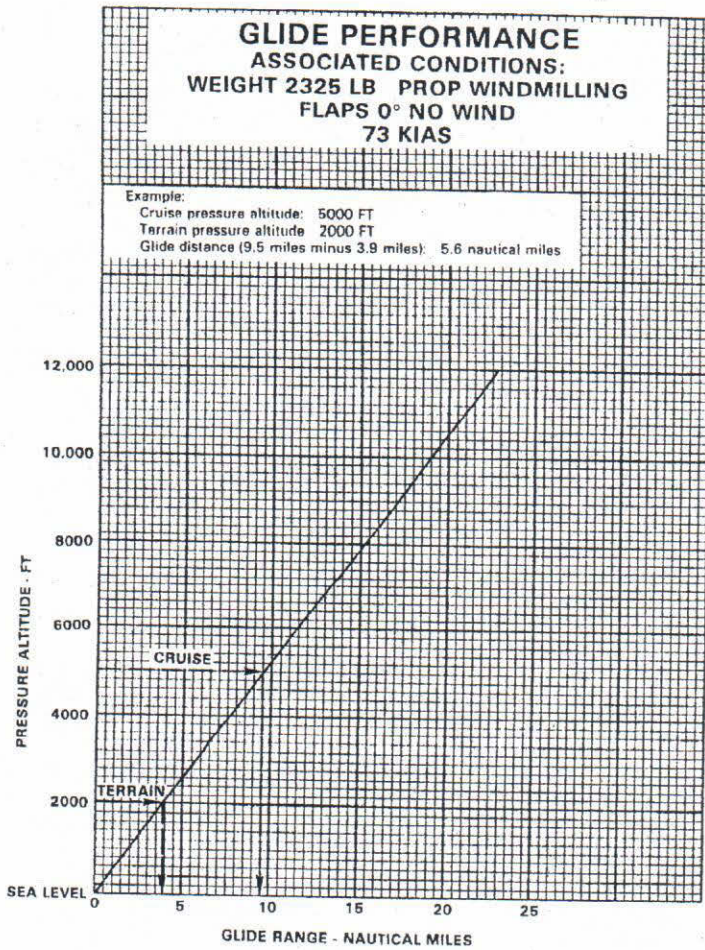

GLIDE PERFORMANCE
Figure 5-33

ISSUED: SEPTEMBER 9, 1988
REVISED: DECEMBER 16, 1988

REPORT: VB-1360
5-27

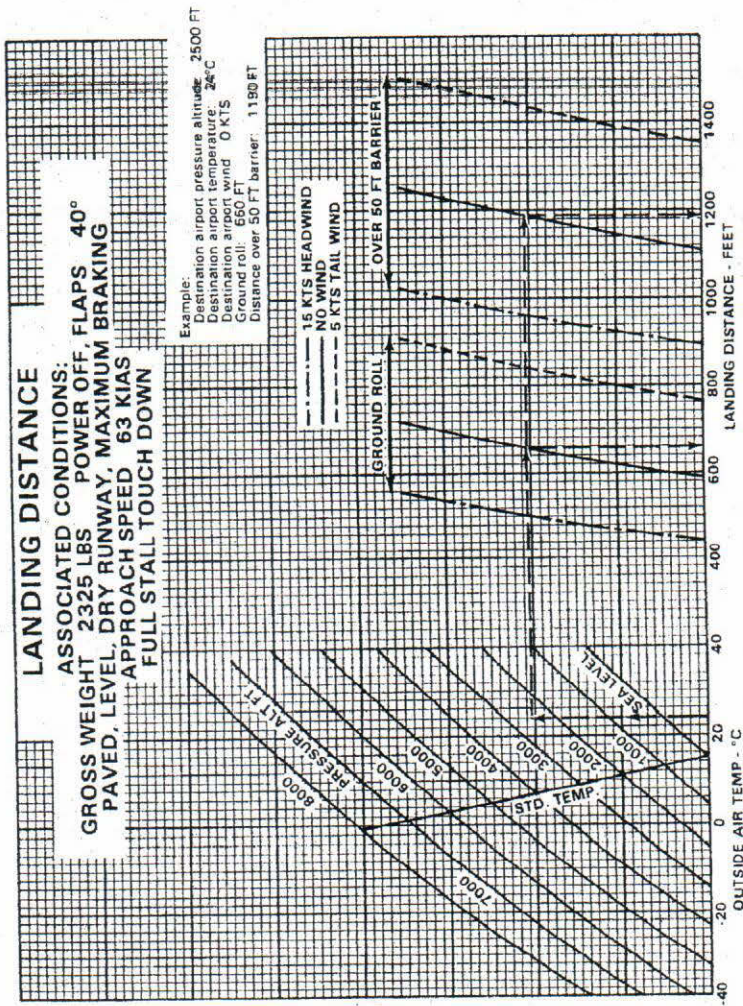

LANDING DISTANCE

Figure 5-35

TABLE OF CONTENTS
SECTION 6
WEIGHT AND BALANCE

Paragraph No.		Page No.
6.1	General	6-1
6.3	Airplane Weighing Procedure	6-2
6.5	Weight and Balance Data and Record	6-6
6.7	Weight and Balance Determination for Flight	6-11
6.9	Instructions for Using the Weight and Balance Plotter	6-14

SECTION 6
WEIGHT AND BALANCE

6.1 GENERAL

In order to achieve the performance and flying characteristics which are designed into the airplane, it must be flown with the weight and center of gravity (C.G.) position within the approved operating range (envelope). Although the airplane offers a flexibility of loading, it cannot be flown with the maximum number of adult passengers, full fuel tanks, maximum baggage, and full options. With this loading flexibility comes responsibility. The pilot must ensure that the airplane is loaded within the loading envelope before takeoff.

Misloading carries consequences for any aircraft. An overloaded airplane will not take off, climb or cruise as well as a properly loaded one. The heavier the airplane is loaded, the less climb performance it will have.

Center of gravity is a determining factor in flight characteristics. If the C.G. is too far forward in any airplane, it may be difficult to rotate for takeoff or landing. If the C.G. is too far aft, the airplane may rotate prematurely on takeoff or tend to pitch up during climb. Longitudinal stability will be reduced. This can lead to inadvertent stalls and even spins; and spin recovery becomes more difficult as the center of gravity moves aft of the approved limit.

A properly loaded airplane, however, will perform as intended. Before the airplane is licensed, it is weighed, and a basic empty weight and C.G. location is computed (basic empty weight consists of the standard empty weight of the airplane plus the optional equipment). Using the basic empty weight and C.G. location, the pilot can easily determine the weight and C.G. position for the loaded airplane by computing the total weight and moment and then determining whether they are within the approved envelope.

The basic empty weight and C.G. location are recorded in the Weight and Balance Data Form (Figure 6-5) and the Weight and Balance Record (Figure 6-7). The current values should always be used. Whenever new equipment is added or any modification work is done, the mechanic responsible for the work is required to compute a new basic empty weight and C.G. position and to write these in the Aircraft Log Book and the Weight and Balance Record. The owner should make sure that it is done.

A weight and balance calculation is necessary in determining how much fuel or baggage can be loaded so as to keep within allowable limits. Check calculations prior to adding fuel to ensure against improper loading.

The following pages are forms used in weighing an airplane in production and in computing basic empty weight, C.G. position, and useful load. Note that the useful load includes usable fuel, baggage, cargo and passengers. Following this is the method for computing takeoff weight and C.G.

6.3 AIRPLANE WEIGHING PROCEDURE

At the time of licensing, Piper Aircraft Corporation provides each airplane with the basic empty weight and center of gravity location. This data is supplied by Figure 6-5.

The removal or addition of equipment or airplane modifications can affect the basic empty weight and center of gravity. The following is a weighing procedure to determine this basic empty weight and center of gravity location:

(a) Preparation

- (1) Be certain that all items checked in the airplane equipment list are installed in the proper location in the airplane.
- (2) Remove excessive dirt, grease, moisture, and foreign items, such as rags and tools, from the airplane before weighing.

- (3) Defuel airplane. Then open all fuel drains until all remaining fuel is drained. Operate engine on each tank until all undrainable fuel is used and engine stops. Then add the unusable fuel (2.0 gallons total, 1.0 gallon each wing).

CAUTION

Whenever the fuel system is completely drained and fuel is replenished, it will be necessary to run the engine for a minimum of three minutes at 1000 RPM on each tank to insure no air exists in the fuel supply lines.

- (4) Fill with oil to full capacity.
- (5) Place pilot and copilot seats in fourth (4th) notch, aft of forward position. Put flaps in fully retracted position and all control surfaces in the neutral position. Tow bar should be in the proper location and entrance door should be closed.
- (6) Weigh the airplane inside a closed building to prevent errors in the scale readings due to wind.

(b) Leveling

- (1) With airplane on scales, block main gear oleo pistons in the fully extended position.
- (2) Level airplane (refer to Figure 6-3) by deflating the nose wheel tire to center bubble on level.

**SECTION 6
WEIGHT AND BALANCE**

**PIPER AIRCRAFT CORPORATION
PA-28-161, CADET**

(c) Weighing - Airplane Basic Empty Weight

With the airplane level and brakes released, record the weight shown on each scale. Deduct the tare, if any, from each reading.

Scale Position and Symbol	Scale Reading	Tare	Net Weight
Nose Wheel (N)			
Right Main Wheel (R)			
Left Main Wheel (L)			
Basic Empty Weight, (as Weighed) (T)	—	—	

WEIGHING FORM
Figure 6-1

(d) Basic Empty Weight Center of Gravity

- (1) The following geometry applies to the PA-28-161 airplane when it is level. Refer to Leveling paragraph 6.3 (b).

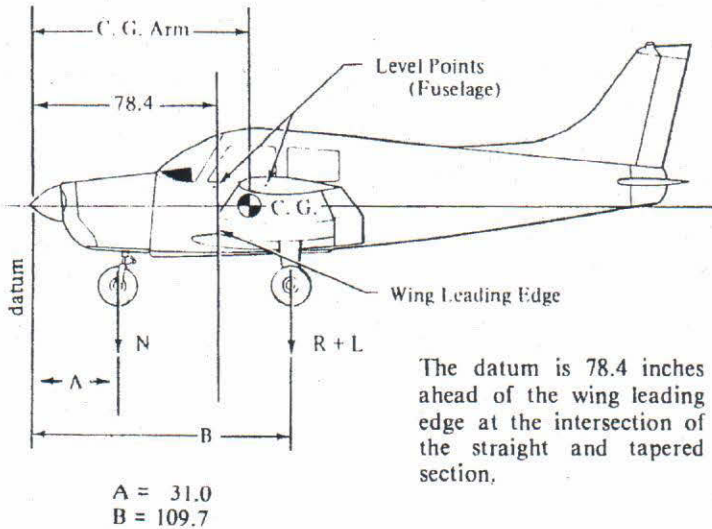

LEVELING DIAGRAM

Figure 6-3

- (2) The basic empty weight center of gravity (as weighed including optional equipment, full oil and unusable fuel) can be determined by the following formula:

$$\text{C.G. Arm} = \frac{N(A) + (R + L)(B)}{T} \text{ inches}$$

Where: $T = N + R + L$

6.5 WEIGHT AND BALANCE DATA AND RECORD

The Basic Empty Weight, Center of Gravity Location and Useful Load listed in Figure 6-5 are for the airplane as licensed at the factory. These figures apply only to the specific airplane serial number and registration number shown.

The basic empty weight of the airplane as licensed at the factory has been entered in the Weight and Balance Record (Figure 6-7). This form is provided to present the current status of the airplane basic empty weight and a complete history of previous modifications. Any change to the permanently installed equipment or modification which affects weight or moment must be entered in the Weight and Balance Record and Equipment List.

MODEL PA-28-161, CADET

Airplane Serial Number _____

Registration Number _____

Date _____

AIRPLANE BASIC EMPTY WEIGHT

Item	Weight (Lbs)	x C.G. Arm (Inches Aft of Datum)	= Moment (In-Lbs)
Standard Empty Weight* Actual Computed			
Optional Equipment			
Basic Empty Weight			

*The standard empty weight includes full oil capacity and 2.0 gallons of unusable fuel.

AIRPLANE USEFUL LOAD

(Ramp Weight) - (Basic Empty Weight) = Useful Load

(Normal Category: (2332 lbs) - (lbs) = lbs

(Utility Category: (2027 lbs) - (lbs) = lbs

THIS BASIC EMPTY WEIGHT, C.G., AND USEFUL LOAD ARE FOR THE AIRPLANE AS LICENSED AT THE FACTORY. REFER TO APPROPRIATE AIRCRAFT RECORD WHEN ALTERATIONS HAVE BEEN MADE.

WEIGHT AND BALANCE DATA FORM

Figure 6-5

ISSUED: SEPTEMBER 9, 1988
 REVISED: APRIL 4, 1989

REPORT: VB-1360
 6-7

**SECTION 6
WEIGHT AND BALANCE**

**PIPER AIRCRAFT CORPORATION
PA-28-161, CADET**

PA-28-161	Serial Number	Registration Number			Page Number		
		Added (+) Removed (-)	Weight Change	Wt. (Lb.)	Running Basic Empty Weight	Wt. (Lb.)	Moment / 100
Date	Description of Article or Modification As licensed		Wt. (Lb.)	Arm (In.)	Moment / 100		
Item No.							

WEIGHT AND BALANCE RECORD
Figure 6-7

PA-28-161	Serial Number		Registration Number			Page Number	
	Date	Item No.	Description of Article or Modification	Added (+) Removed (-)	Wt. (Lb.)	Arm (In.)	Moment /100
		Weight Change		Running Basic Empty Weight	Wt. (Lb.)	Moment /100	

WEIGHT AND BALANCE RECORD (cont)
 Figure 6-7 (cont)

6.7 WEIGHT AND BALANCE DETERMINATION FOR FLIGHT

- (a) Add the weight of all items to be loaded to the basic empty weight.
- (b) Use the Loading Graph (Figure 6-13) to determine the moment of all items to be carried in the airplane.
- (c) Add the moment of all items to be loaded to the basic empty weight moment.
- (d) Divide the total moment by the total weight to determine the C.G. location.
- (e) By using the figures of item (a) and item (d) (above), locate a point on the C.G. range and weight graph (Figure 6-15). If the point falls within the C.G. envelope, the loading meets the weight and balance

	Weight (Lbs)	Arm Aft Datum (Inches)	Moment (In-Lbs)
Basic Empty Weight	1505	85.9	129279.5
Pilot and Front Passenger	340.0	80.5	27370
Passengers (Optional Rear Seat)*	170.0	118.1	20077
Fuel (48 Gallon Maximum)	267	95.0	25365
Baggage* (50 Lbs. Maximum)	50	142.8	7140
Ramp Weight (2332 Lbs. Normal, 2027 Lbs. Utility Maximum)	2332	89.72	209231.5
Fuel Allowance For Engine Start, Taxi & Runup	-7	95.0	-665
Take-off Weight (2325 Lbs. Normal, 2020 Lbs. Utility Maximum)	2325	89.7	208566.5

The center of gravity (C.G.) of this sample loading problem is at 89.68 inches aft of the datum line. Locate this point (89.68) on the C.G. range and weight graph. Since this point falls within the weight - C.G. envelope, this loading meets the weight and balance requirements.

IT IS THE RESPONSIBILITY OF THE PILOT AND AIRCRAFT OWNER TO ENSURE THAT THE AIRPLANE IS LOADED PROPERLY.

*Utility Category Operation - No baggage or aft passengers allowed.

SAMPLE LOADING PROBLEM (NORMAL CATEGORY)

Figure 6-9

	Weight (Lbs)	Arm Aft Datum (Inches)	Moment (In-Lbs)
Basic Empty Weight			
Pilot and Front Passenger		80.5	
Passengers (Optional Rear Seat)*		118.1	
Fuel (48 Gallon Maximum)		95.0	
Baggage* (50 Lbs. Maximum)		142.8	
Ramp Weight (2332 Lbs. Normal, 2027 Lbs. Utility Maximum)			
Fuel Allowance For Engine Start, Taxi and Run Up	-7	95.0	-665
Total Loaded Airplane (2325 Lbs. Normal, 2020 Lbs. Utility Maximum)			

Totals must be within approved weight and C.G. limits. It is the responsibility of the airplane owner and the pilot to ensure that the airplane is loaded properly. The Basic Empty Weight C.G. is noted on the Weight and Balance Data Form (Figure 6-5). If the airplane has been altered, refer to the Weight and Balance Record for this information.

*Utility Category Operation - No baggage or aft passengers allowed.

WEIGHT AND BALANCE LOADING FORM
 Figure 6-11

SECTION 6
WEIGHT AND BALANCE

PIPER AIRCRAFT CORPORATION
PA-28-161, CADET

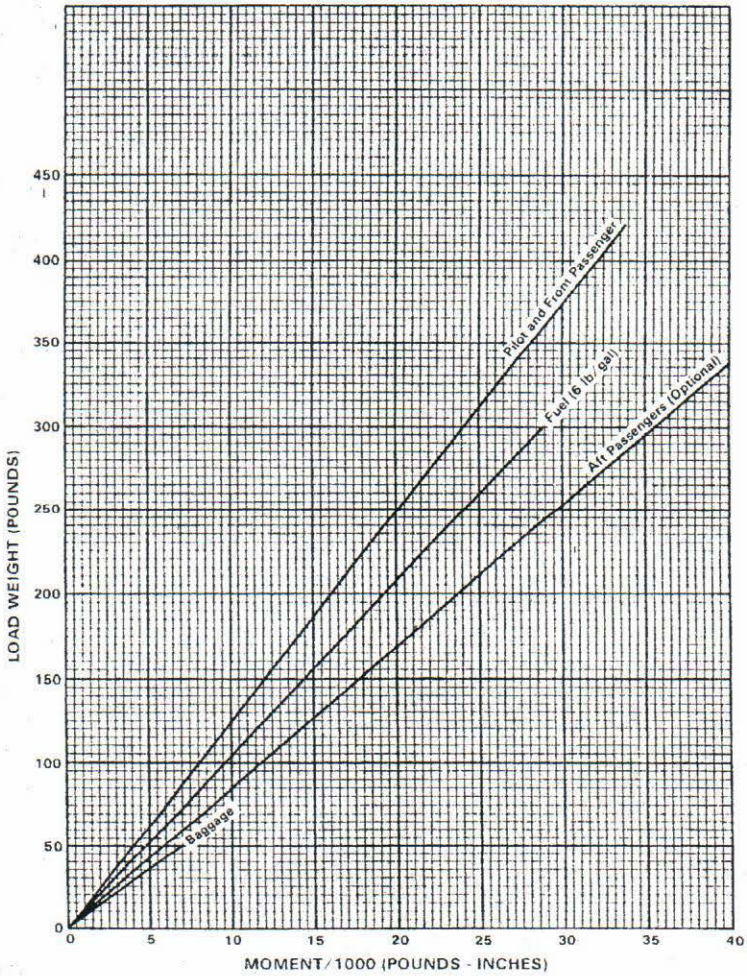

LOADING GRAPH

Figure 6-13

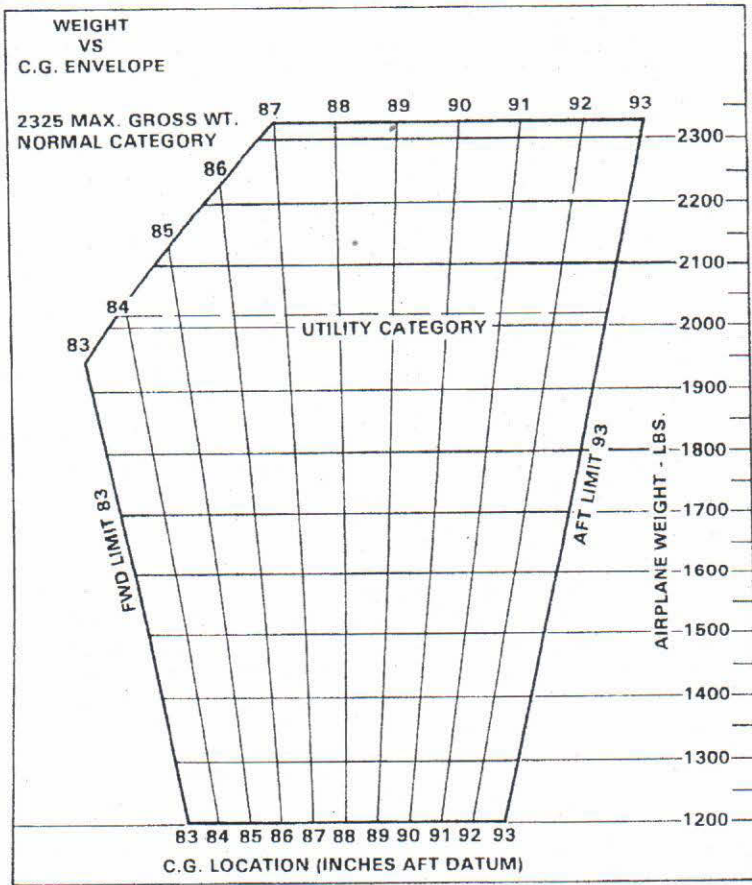

C.G. RANGE AND WEIGHT
Figure 6-15

6.9 INSTRUCTIONS FOR USING THE WEIGHT AND BALANCE PLOTTER

This plotter is provided to enable the pilot quickly and conveniently to:

- (a) Determine the total weight and C.G. position.
- (b) Decide how to change the load if the first loading is not within the allowable envelope.

Heat can warp or ruin the plotter if it is left in the sunlight. Replacement plotters may be purchased from Piper dealers and distributors.

The Basic Empty Weight and Center of Gravity location is taken from the Weight and Balance Data Form (Figure 6-5), the Weight and Balance Record (Figure 6-7), or the latest FAA major repair or alteration form.

The plotter enables the user to add weights and corresponding moments graphically. The effect of adding or disposing of useful load can easily be seen. The plotter does not cover the situation where cargo is loaded in locations other than on the seats or in the baggage compartments.

To use the plotter, first plot a point on the grid to locate the basic weight and C.G. location. This can be put on more or less permanently because it will not change until the airplane is modified. Next, position the zero weight end of any one of the loading slots over this point. Using a pencil, draw a line along the slot to the weight which will be carried in that location. Then position the zero weight end of the next slot over the end of this line and draw another line representing the weight which will be located in this second position. When all the loads, except fuel, have been drawn in this manner, the end of the segmented line locates the load and the C.G. position of the airplane for zero fuel weight. If this point is not within the allowable envelope, it will be necessary to remove baggage or passengers, and/or to rearrange baggage and passengers to get the point to fall within the envelope.

Position the zero fuel weight end of the fuel slot over this point and draw a line representing fuel load. The end of the segmented line locates the load and C.G. position of the airplane for Ramp Weight. If this is not within the allowable envelope, it will be necessary to remove fuel, baggage, or passengers and/or rearrange baggage and passengers to get this final point to fall within the envelope.

Fuel allowance for engine start, taxi, and runup is 7 pounds.

6.9 INSTRUCTIONS FOR USING THE WEIGHT AND BALANCE PLOTTER (Continued)

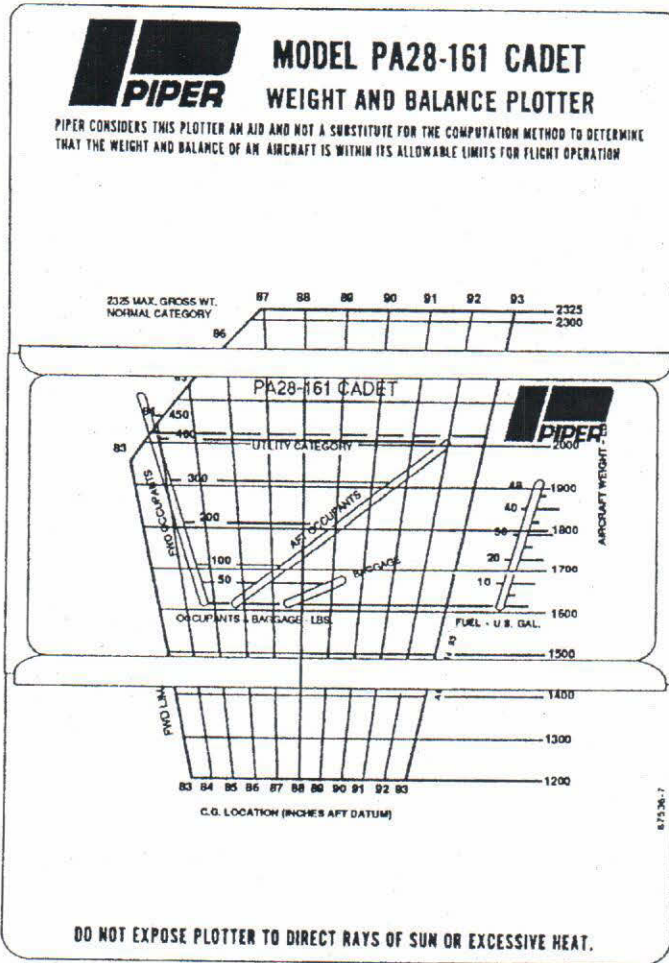

WEIGHT AND BALANCE PLOTTER
 Figure 6-17

6.9 INSTRUCTIONS FOR USING THE WEIGHT AND BALANCE
PLOTTER (Continued)

SAMPLE PROBLEM

A sample problem will demonstrate the use of the weight and balance plotter. Assume a basic weight and C.G. location of 1505 pounds at 85.9 inches respectively. We wish to carry one pilot and two passengers: the pilot and one passenger will occupy the front seats, one passenger will occupy the rear seat. Each occupant weighs 170 pounds. We wish to carry 50 pounds of baggage in the rear baggage compartment. We wish to carry 44.5 gallons of fuel. Will we be within the safe envelope?

- (1) Place a dot on the plotter grid at 1505 pounds and 85.9 inches to represent the basic airplane (see Figure 6-19).
- (2) Slide the slotted plastic into position so that the dot is under the slot for the forward seats (pilot and front passenger) at zero weight.
- (3) Draw a line up the slot to the 340 pound position ($170 + 170$) and place a dot.
- (4) Slide the slotted plastic into position so that the zero end of the rear seat slot is over this dot.
- (5) Draw a line up the slot to the 170 pound position and place the third dot.
- (6) Continue moving the plastic and plotting points to account for weight in the rear baggage compartment (50 pounds) and fuel tanks (267 pounds; 44.5 gallons).
- (7) As can be seen from Figure 6-19, the final dot shows the total ramp weight to be 2332 pounds with the C.G. at 89.7 inches. This point is within the weight and C.G. limits.
- (8) Fuel allowance for engine start, taxi, and runup is 7 pounds.

As fuel is burned off, the weight and C.G. will follow down the fuel line and stay within the envelope for landing.

6.9 INSTRUCTIONS FOR USING THE WEIGHT AND BALANCE PLOTTER (Continued)

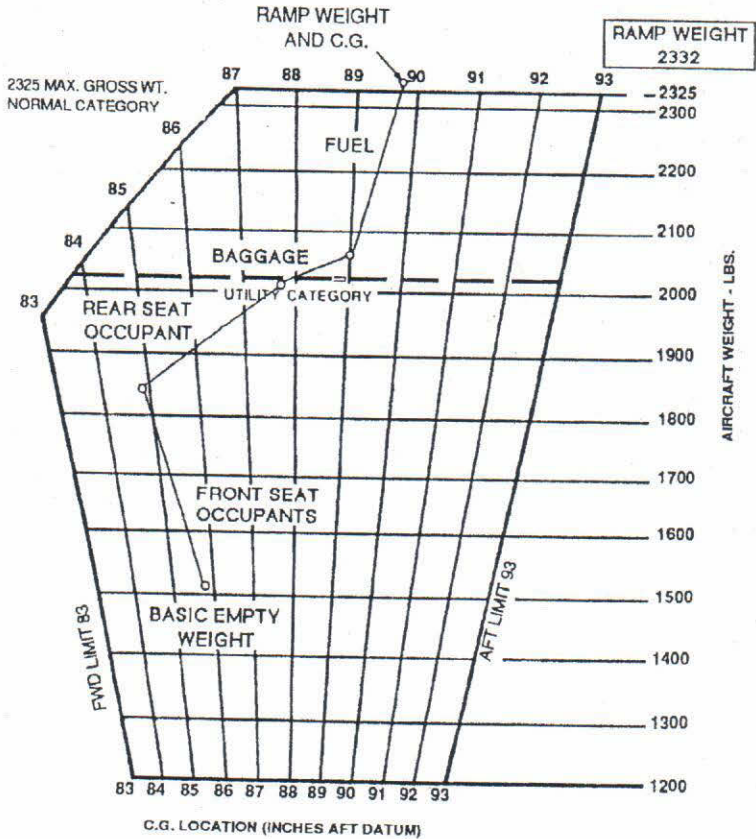

SAMPLE PROBLEM
Figure 6-19

THIS PAGE INTENTIONALLY LEFT BLANK

TABLE OF CONTENTS
SECTION 7
DESCRIPTION AND OPERATION
OF THE AIRPLANE AND ITS SYSTEMS

Paragraph No.		Page No.
7.1	The Airplane	7-1
7.3	Airframe	7-1
7.5	Engine and Propeller	7-2
7.7	Landing Gear	7-4
7.9	Flight Controls	7-5
7.11	Engine Controls	7-6
7.13	Fuel System	7-8
7.15	Electrical System	7-10
7.17	Vacuum System	7-13
7.19	Instrument Panel	7-15
7.21	Pitot-Static System	7-18
7.23	Heating and Ventilating System	7-21
7.25	Cabin Features	7-21
7.27	Baggage Area	7-22
7.29	Stall Warning	7-22
7.31	Finish	7-22
7.33	Piper External Power	7-23
7.35	Emergency Locator Transmitter	7-23
7.37	Air Conditioning	7-25
7.39	Carburetor Ice Detection System	7-26

1
2
3
4
5
6
7
8
9
10
11
12
13
14
15
16
17
18
19
20
21
22
23
24
25
26
27
28
29
30
31
32
33
34
35
36
37
38
39
40
41
42
43
44
45
46
47
48
49
50
51
52
53
54
55
56
57
58
59
60
61
62
63
64
65
66
67
68
69
70
71
72
73
74
75
76
77
78
79
80
81
82
83
84
85
86
87
88
89
90
91
92
93
94
95
96
97
98
99
100

SECTION 7

DESCRIPTION AND OPERATION OF THE AIRPLANE AND ITS SYSTEMS

7.1 THE AIRPLANE

The Cadet, designed and equipped for pilot training, is a single-engine, fixed gear monoplane of all metal construction, with low semi-tapered wings. The standard airplane has two place seating, with an optional bench seat available to provide four place seating. The baggage capacity is fifty pounds with either seating configuration.

7.3 AIRFRAME

The primary structure, with the exception of the steel tube engine mount, steel landing gear struts and isolated areas, is of aluminum alloy construction. Lightweight plastics are used extensively in the extremities - the wing tips, the engine cowling, etc - and in nonstructural components throughout the airplane.

The fuselage is a conventional semi-monocoque structure. On the right side of the airplane is a cabin door for entrance and exit. Access to the baggage area is gained through the cabin entrance.

The wing is of a conventional, semi-tapered design incorporating a laminar flow, NACA 652415, airfoil section. The cantilever wings are attached to each side of the fuselage by insertion of the butt ends of the main spars into a spar box carry-through which is an integral part of the fuselage structure. The spar box carry-through structure, located beneath the floor behind the pilots' seats, provides in effect a continuous main spar. The wings are also attached fore and aft of the main spar by an auxiliary front spar and a rear spar. The rear spar, in addition to taking torque and drag loads, provides a mount for flaps and ailerons. The four-position wing flaps are mechanically controlled by a handle located between the front seats. When fully retracted, the right flap locks into place to provide a step for cabin entry. Each wing contains one fuel tank.

The empennage consists of a vertical stabilizer, a rudder, and an all-moveable horizontal stabilator. The stabilator incorporates an anti-servo tab which improves longitudinal stability and provides longitudinal trim. The tab moves in the same direction as the stabilator, but with increased travel.

7.5 ENGINE AND PROPELLER

The PA-28-161 is powered by a four cylinder, direct drive, horizontally opposed engine rated at 160 hp at 2700 rpm. It is equipped with a starter, a 60 amp 14 volt alternator, a shielded ignition, two magnetos, vacuum pump drive, a fuel pump, and a wetted polyurethane foam induction air filter.

The engine compartment is accessible for inspection through top-hinged side panels on either side of the engine cowlings. The engine cowlings are cantilever structures attached at the firewall. The engine mounts are constructed of steel tubing, and dynafocal mounts are provided to reduce vibration.

The exhaust system is constructed of stainless steel and incorporates dual mufflers with heater shrouds to supply heated air for the cabin, the defroster system and the carburetor deicing system.

An oil cooler is located on the left rear of the engine mounted to the engine baffling. Engine cooling air, which is picked up in the nose section of the engine cowling and carried through the baffling, is utilized on the left side for the oil cooler. A winterization plate is provided to restrict air during winter operation (refer to Section 8).

Engine air enters on either side of the propeller through openings in a nose cowling and is carried through the engine baffling around the engine and oil cooler. Air for the muffler shroud is also picked up from the nose cowling and carried through a duct to the shroud. Carburetor induction air enters a chin scoop on the lower right cowling and is passed through a wetted polyurethane filter to the carburetor air box. Heated air enters the carburetor air box through a hose connected to the heater shroud.

A fixed pitch propeller is installed as standard equipment. The propeller has a 74-inch diameter with a 58 or 60-inch pitch. The pitch is determined at 75% of the diameter. The propeller is made of an aluminum alloy.

The pilot should read and follow the procedures recommended in the Lycoming Operator's Manual for this engine in order to obtain maximum engine efficiency and time between engine overhauls.

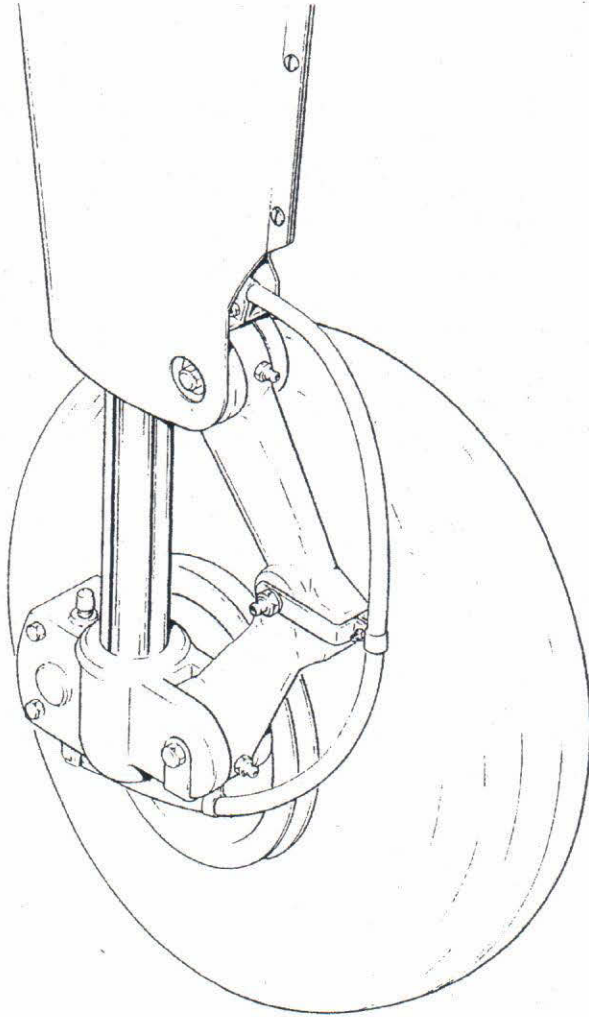

MAIN WHEEL ASSEMBLY
Figure 7-1

ISSUED: SEPTEMBER 9, 1988

REPORT: VB-1360
7-3

7.7 LANDING GEAR

The fixed-gear PA-28-161 is equipped with a 5.00 x 5 wheel on the nose gear and a 6.00 x 6 wheel on each main gear (Figure 7-1). Single disc hydraulic brake assemblies are provided on the main gear. The nose gear has a 5.00 x 5 four-ply tire, while the main wheel assemblies have 6.00 x 6 four-ply tires. At gross weight, the main gear tires require a pressure of 24 psi, and the nose gear tire requires a pressure of 30 psi.

A spring device is incorporated in the rudder pedal torque tube assembly to provide rudder trim. By using the rudder pedals and the brakes, the nose gear is steerable through a 20 degree arc each side of center. A shimmy dampener is also included in the nose gear.

The three struts are of the air-oil type with the normal static load extension being 3.25 inches for the nose gear and 4.50 inches for the main gear.

The brakes are actuated by toe brake pedals which are attached to the rudder pedals or by a hand lever and master cylinder located below and behind the center of the instrument sub panel. Hydraulic cylinders are located above each pedal and adjacent to the hand brake lever. The brake fluid reservoir is installed on the top left front face of the fire wall. The parking brake is incorporated in the master cylinder and is actuated by pulling back on the brake lever and depressing the knob attached to the left side of the handle. To release the parking brake, pull back on the brake lever to disengage the catch mechanism and allow the handle to swing forward (refer to Figure 7-5).

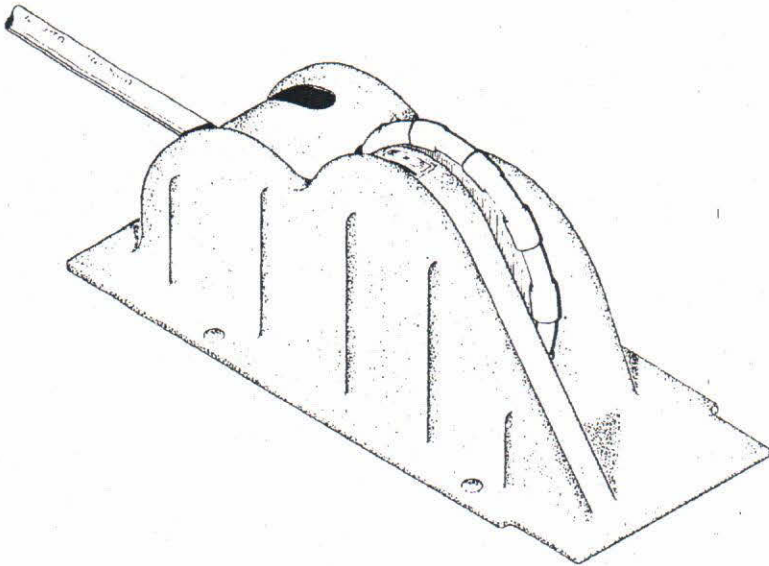

FLIGHT CONTROL CONSOLE

Figure 7-3

7.9 FLIGHT CONTROLS

Dual flight controls are provided as standard equipment. The flight controls actuate the control surfaces through a cable system.

The horizontal surface (stabilator) is of the flying tail design with a trim tab mounted on the trailing edge. This tab serves the dual function of providing trim control and pitch control forces. The trim tab is actuated by a trim control wheel located on the control console between the front seats (Figure 7-3). Forward rotation of the wheel gives nose down trim and aft rotation gives nose up trim.

The rudder is conventional in design and incorporates a rudder trim. The trim mechanism is a spring loaded recentering device. The trim control is located on the right side of the pedestal below the throttle quadrant (refer to Figure 7-5). Turning the trim control clockwise gives nose right trim and counterclockwise rotation gives nose left trim.

Manually controlled flaps are provided on the PA-28-161. The flaps are balanced and spring loaded to return to the retracted (up) position. A control handle, which is located between the two front seats on the control console (Figure 7-3), extends the flaps by the use of a control cable. To extend the flaps, the handle is pulled up to the desired flap setting of 10, 25 or 40 degrees. To retract, depress the button on the end of the handle and lower the control. When extending or retracting flaps, there is a pitch change in the airplane. This pitch change can be corrected either by stabilator trim or increased control wheel force. When the flaps are in the retracted (up) position the right flap, provided with an over-center lock mechanism, acts as a step.

NOTE

The right flap will support a load only in the fully retracted (up) position. When the flap is to be used as a step, make sure the flaps are in the retracted (up) position.

7.11 ENGINE CONTROLS

Engine controls consist of a throttle control and a mixture control lever. These controls are located on the control quadrant on the lower center of the instrument panel (Figure 7-5) where they are accessible to both the pilot and the copilot. The controls utilize teflon-lined control cables to reduce friction and binding.

The throttle lever is used to adjust engine rpm. The mixture control lever is used to adjust the air to fuel ratio. The engine is shut down by the placing of the mixture lever in the full lean position. For information on the leaning procedure, see the Avco-Lycoming Operator's Manual.

The friction adjustment lever on the right side of the control quadrant may be adjusted to increase or decrease the friction holding the throttle and mixture controls or to lock the controls in a selected position.

The carburetor heat control lever is located to the right of the control quadrant on the instrument panel. The control is placarded with two positions: ON (down), OFF (up).

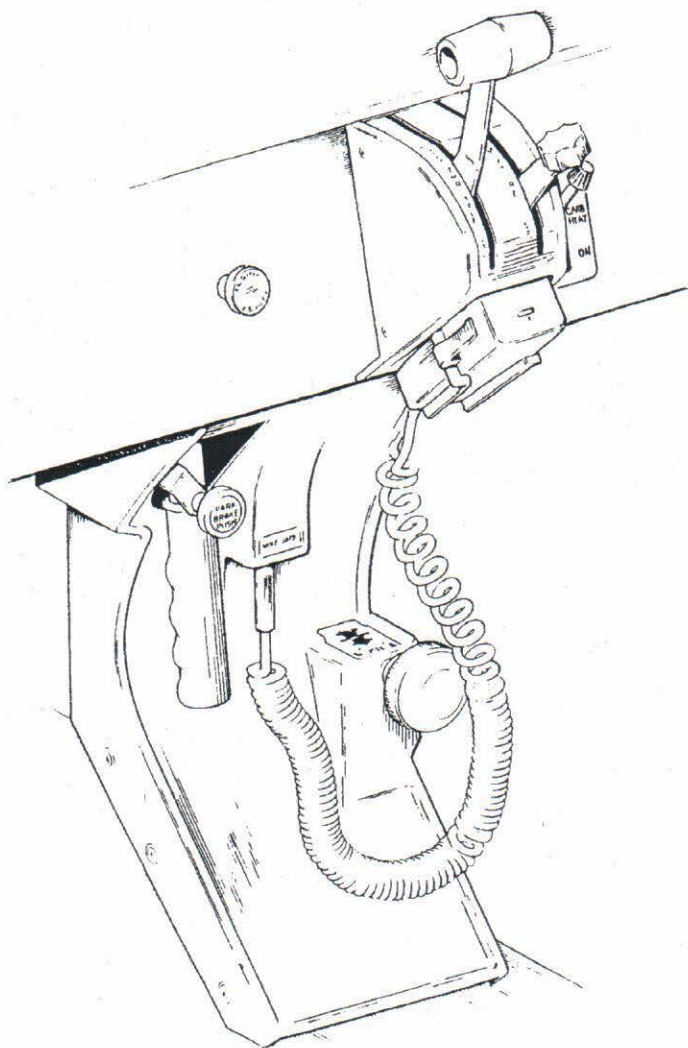

CONTROL QUADRANT AND CONSOLE
Figure 7-5

ISSUED: SEPTEMBER 9, 1988
REVISED: NOVEMBER 27, 1989

REPORT: VB-1360 |
7-7

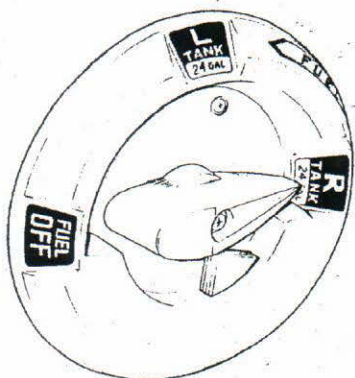

FUEL SELECTOR

Figure 7-7

7.13 FUEL SYSTEM

The Cadet has a total fuel capacity of 50 U.S. gallons stored in two 25 gallon wing tanks. Only 24 gallons of fuel are usable from each tank, which provides a total usable fuel capacity of 48 gallons. Each tank is equipped with a filler neck indicator tab to aid in determining fuel remaining when the tanks are not full. Usable capacity to the bottom of the indicator tab is 17 gallons. The tanks are secured to the leading edge of each wing with screws and nut plates. This allows removal for service or inspection.

The fuel tank selector control (Figure 7-7) is located on the left side panel forward of the pilot's seat. The button on the selector cover must be depressed and held while the handle is moved to the OFF position. The button releases automatically when the handle is moved back to the ON position.

An auxiliary electric fuel pump is provided in case of the failure of the engine-driven pump. The electric pump should be ON for all takeoffs and landings and when switching tanks. The fuel pump switch is located in the switch panel in the center of the instrument panel above the throttle quadrant.

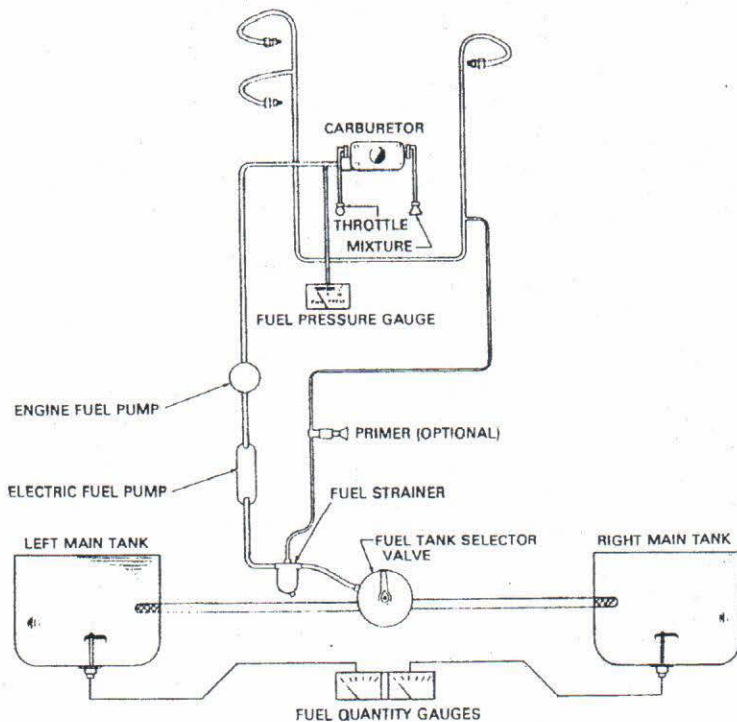

FUEL SYSTEM SCHEMATIC
Figure 7-9

The fuel drains should be opened daily prior to first flight to check for water or sediment and proper fuel. Each tank has an individual drain at the bottom, inboard rear corner. A fuel strainer, located on the lower left front of the firewall, has a drain which is accessible from outside the nose section. The strainer should also be drained before the first flight of the day. Refer to Section 8 for the complete fuel draining procedure.

Optional locking fuel caps are available for all fillers. A single key will fit the fuel caps, cabin door, and ignition lock.

Fuel quantity and fuel pressure gauges are mounted in a gauge cluster located on the left side of the instrument panel to the right of the control wheel (refer to Figure 7-15).

An optional engine priming system is available to facilitate starting. The primer pump is located to the immediate left of the throttle quadrant (refer to Figure 7-5).

7.15 ELECTRICAL SYSTEM

The electrical system includes a 14-volt 60-amp alternator, a 12-volt battery, a voltage regulator, and a master switch relay (Figure 7-11). The battery is in a box mounted on the forward right face of the firewall. The voltage regulator is located on the forward left side of the fuselage behind the instrument panel.

Electrical switches are located on the right center instrument panel (refer to Figure 7-15), and the circuit breakers are located on the lower right instrument panel (refer to Figure 7-13). Two rheostat switches on the pilot's lower left instrument panel adjacent to the engine instruments control the switch, radio, and panel lights.

Standard electrical accessories include a starter, electric fuel pump, stall warning indicator, fuel gauge, ammeter, and annunciator panel.

The annunciator panel (Figure 7-15) contains alternator (ALT), low oil pressure (OIL), and low vacuum (VAC) warning lights. The annunciators are provided only to alert the pilot that a system may not be operating properly. If an annunciator light illuminates, the pilot should monitor the applicable system gauge to determine when, or if, any corrective action is necessary.

Electrical lighting accessories include navigation lights, landing light, instrument lighting, and cabin dome light. A light mounted in the cabin overhead panel just forward of the dome light, and controlled by an adjacent rheostat switch, provides additional instrument and cockpit lighting for night flying. The lens of this light has a map light window, which is opened or closed by a slide type switch just forward of the window. Circuits will also handle the addition of communications and navigational equipment.

Optional electrical accessories include anti-collision lights, wing tip recognition/taxi lights, and an external power receptacle and power cable.

WARNING

Anti-collision lights should not be operating when flying through cloud, fog or haze, since the reflected light can produce spatial disorientation. Strobe lights should not be used in close proximity to the ground such as during taxiing, takeoff or landing.

As installed, the ammeter does not show battery discharge; rather, it indicates the electrical load on the alternator in amperes. With all the electrical equipment off and the battery master and alternator switches on, the ammeter will indicate the charging rate of the battery. As each electrical unit is switched on, the ammeter will indicate the total amperage draw of all the units including the battery. For example, the average continuous load for night flight with radios on is about 30 amperes. This 30 ampere value plus approximately 2 amperes for a fully charged battery will appear continuously under these flight conditions. The amount of current shown on the ammeter will tell immediately if the alternator system is operating normally, as the amount of current shown should equal the total amperage drawn by the electrical equipment which is operating.

For abnormal and/or emergency operation and procedures, see Section 3.

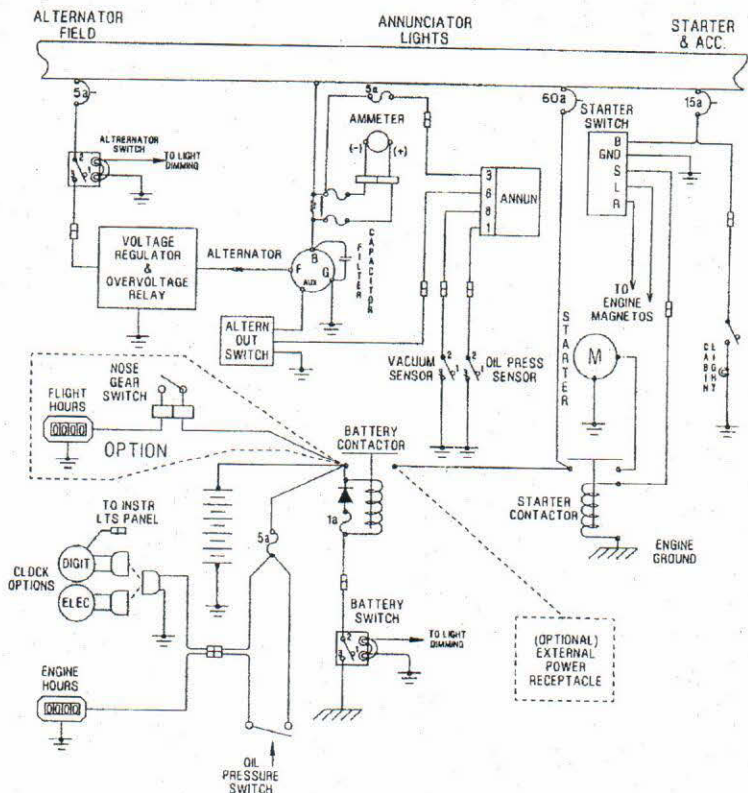

ALTERNATOR AND STARTER SCHEMATIC
Figure 7-11

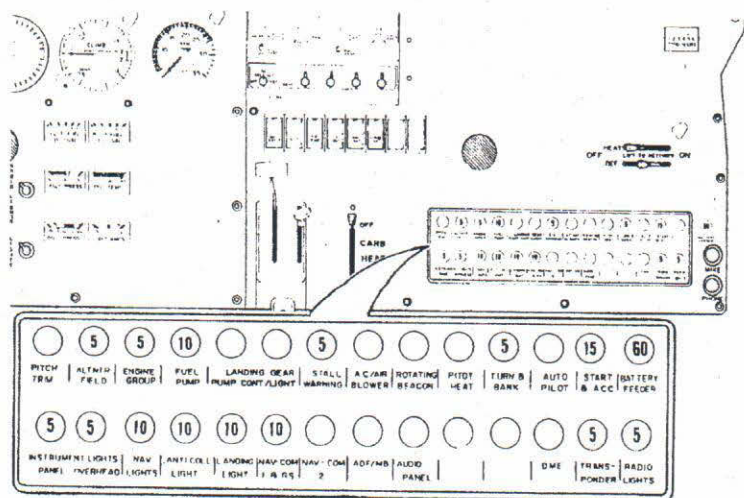

CIRCUIT BREAKER PANEL

Figure 7-13

7.17 VACUUM SYSTEM

The vacuum system is designed to operate the air-driven directional and attitude gyro instruments. The system consists of an engine driven dry-type vacuum pump, a vacuum regulator, a filter, and the necessary plumbing. A shear drive protects the pump from damage. If the drive shears, the air driven gyros will become inoperative.

A vacuum gauge, mounted on the far right instrument panel, provides a pilot check for the system during operation. Should system vacuum pressure decrease below that required for proper operation of the gyro instruments, the VAC light on the annunciator panel will illuminate. A pressure decrease in a system that remained constant over an extended period may indicate a dirty filter, dirty screens, a sticky vacuum regulator, or a leak in the system. Zero pressure would indicate a sheared pump drive, a defective pump, a defective gauge, or a collapsed line. In the event of any gauge variation from the normal, or illumination of the VAC annunciator light, have a mechanic check the system to prevent possible damage to system components or eventual system failure.

The vacuum regulator, located behind the instrument panel, is installed in the system to protect the gyros. The regulator is adjusted so that the vacuum gauge will normally indicate 4.8 to 5.1 inches of mercury, which is sufficient to operate all the gyros at their rated rpm. A higher setting will damage the gyros; at a lower setting the gyros would be unreliable. A low vacuum pressure reading will be observed at very high altitudes (above 12,000 ft), and at low engine rpm (usually during approach or training maneuvers). This is normal and should not be construed as a system malfunction or improperly adjusted regulator.

A standby electric driven vacuum pump is installed in Cadets equipped for IFR flight. Should the primary engine driven pump fail, the standby pump can be switched ON to maintain normal vacuum service to the gyros. (See Section 9, Supplement 4.)

7.19 INSTRUMENT PANEL

The instrument panel (Figure 7-15) is designed to accommodate instruments and avionics equipment for VFR and IFR flights.

The radios and the circuit breakers are located on the center and lower right panel, respectively, and have circuits provided for the addition of optional radio equipment. When installed, the optional radio master switch is located on the switch panel in the center of the instrument panel above the throttle quadrant. It controls the power to all radios through the airplane master switch. An engine cluster is located to the right of the pilot control wheel and includes a fuel pressure gauge, a right and left main fuel quantity gauge, an oil temperature gauge, an oil pressure gauge, and an ammeter.

In addition to the engine cluster, standard instruments include a compass, an airspeed indicator, a tachometer, an altimeter, an ammeter, and an annunciator panel. The compass is mounted on the windshield bow in clear view of the pilot. The annunciator panel is mounted in the upper instrument panel to warn the pilot of a possible malfunction in the alternator, oil pressure, or vacuum systems.

Also included as standard instruments on the Cadet are a suction gauge, vertical speed indicator, attitude gyro, directional gyro, and a turn and slip indicator or turn coordinator. The attitude gyro and directional gyro are vacuum operated through the use of a vacuum pump installed on the engine, while the turn and slip indicator is electrically operated. The vacuum suction gauge is on the far right of the instrument panel.

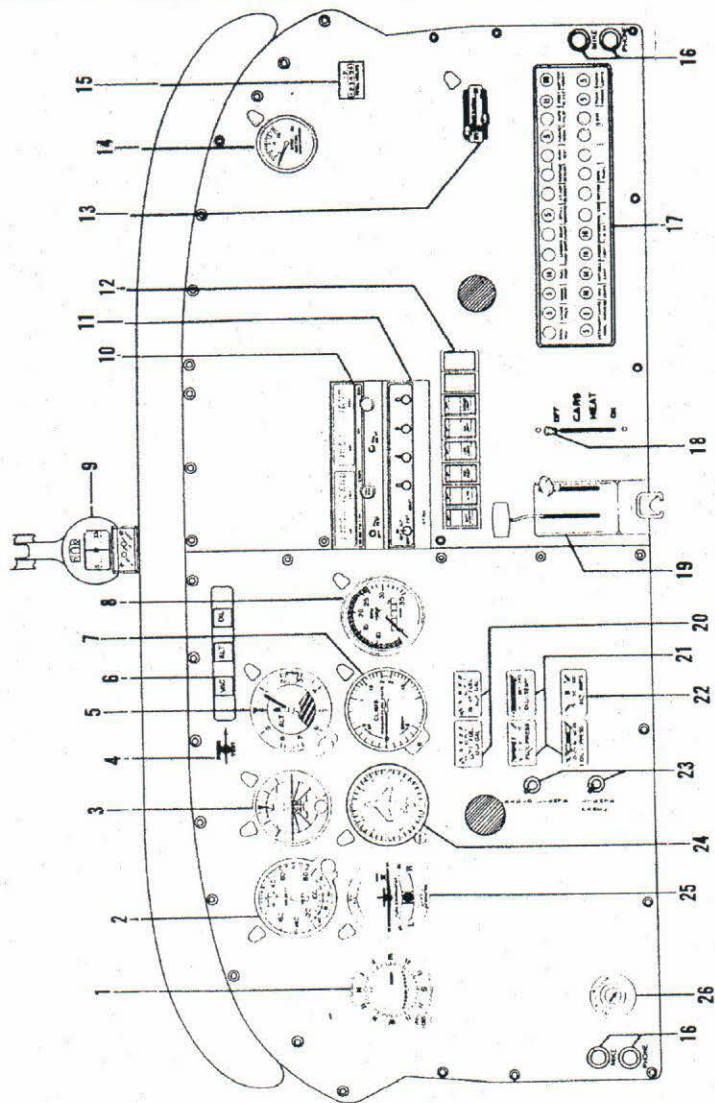

TYPICAL INSTRUMENT PANEL

Figure 7-15

- | | |
|---|---|
| 1. VOR/LOC NAVIGATION INDICATOR | 14. GYRO SUCTION GAUGE |
| 2. AIRSPEED INDICATOR | 15. HOUR METER |
| 3. ATTITUDE GYRO | 16. MIKE AND PHONE JACKS |
| 4. ANNUNCIATOR TEST SWITCH | 17. CIRCUIT BREAKER PANEL |
| 5. ALTIMETER | 18. CARBURETOR HEAT CONTROL |
| 6. ANNUNCIATOR LIGHTS | 19. ENGINE CONTROLS QUADRANT |
| 7. VERTICAL SPEED INDICATOR | 20. LEFT AND RIGHT FUEL GAUGES |
| 8. TACHOMETER | 21. ENGINE INSTRUMENTS |
| 9. MAGNETIC COMPASS | 22. AMMETER |
| 10. NAV/COMM TRANSCIEVER | 23. INSTRUMENT/RADIO/SWITCH
LIGHT CONTROLS |
| 11. TRANSPONDER | 24. DIRECTIONAL GYRO |
| 12. SWITCH PANEL | 25. TURN INDICATOR |
| 13. CABIN HEAT AND
WINDSHIELD DEFROST CONTROLS | 26. MAGNETO SWITCH |

TYPICAL INSTRUMENT PANEL

Figure 7-15 (cont)

7.21 PITOT/STATIC SYSTEM

The system supplies both pitot and static pressure for the airspeed indicator, altimeter, and vertical speed indicator (Figure 7-17).

Pitot and static pressure are picked up by the pitot/static masthead installed on the bottom of the left wing, and carried through pitot and static pressure lines within the wing and fuselage to the gauges on the instrument panel.

An alternate static pressure source control valve is installed below the left side of the instrument panel on Cadets equipped for IFR flight. When the valve is set in the alternate position, the altimeter, vertical speed indicator and airspeed indicator will be using cabin air for static pressure. The storm window and cabin vents must be closed and the cabin heater and defroster must be on during alternate static source operation. The altimeter error is less than 50 feet unless otherwise placarded.

Moisture can be drained from both the pitot and static lines through separate drain valves located in a recess on the left lower side of the fuselage interior.

A heated pitot head, which alleviates problems with icing and heavy rain, is available as optional equipment. The switch for the heated pitot head is located on the switch panel in the center of the instrument panel above the throttle quadrant.

While the airplane is parked, a cover should be placed over the masthead to prevent insects and water from entering the pitot/static orifices. Partially or completely blocked pitot or static vents will result in erroneous, erratic, or zero readings on the associated instruments.

NOTE

During the preflight, check to make sure the pitot cover is removed.

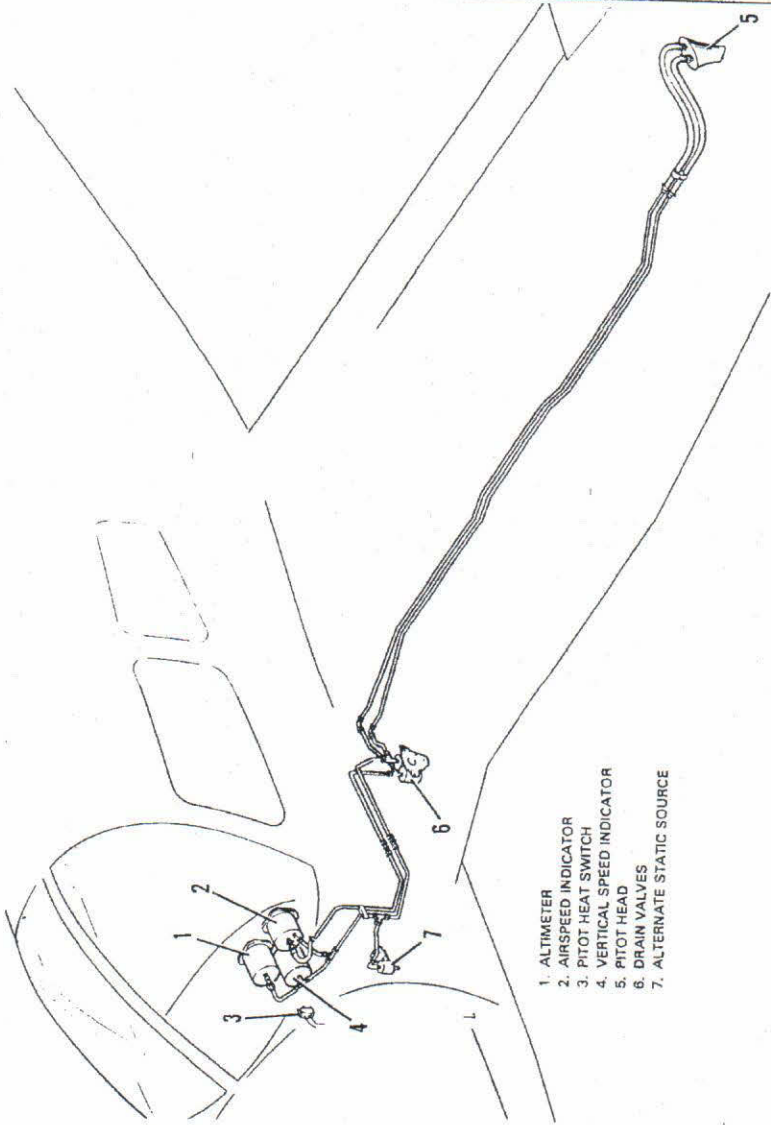

1. ALTIMETER
2. AIRSPEED INDICATOR
3. PITOT HEAT SWITCH
4. VERTICAL SPEED INDICATOR
5. PITOT HEAD
6. DRAIN VALVES
7. ALTERNATE STATIC SOURCE

PITOT-STATIC SYSTEM
Figure 7-17

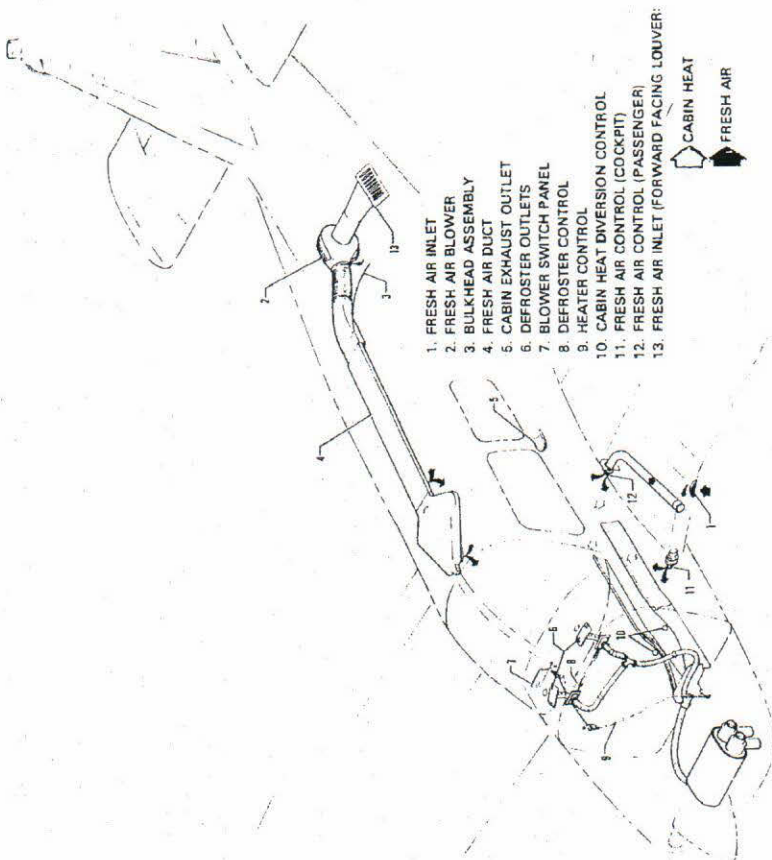

HEATING AND VENTILATING SYSTEM

Figure 7-19

7.23 HEATING AND VENTILATING SYSTEM

Heat for the cabin interior and the defroster system is provided by a shroud attached to the muffler (Figure 7-19). The amount of heat can be regulated with the controls located on the far right side of the instrument panel.

Heated air flows into the cabin through ducting located above the floor between the seats. Two heat diversion controls, located atop the heated air ducts adjacent to the flap control handle, may be moved in a fore or aft direction to regulate airflow between the front and rear cabin areas.

CAUTION

When cabin heat is operated, heat duct surface becomes hot. This could result in burns if arms or legs are placed too close to heat duct outlets or surface.

Fresh air inlets are located in the leading edges of the wings near the fuselage. At each front seat location there is an adjustable fresh air outlet on the side of the cabin near the floor. Rear seat vents are optional. Cabin air is exhausted through outflow vents located on both sides of the aft cabin near the floor, and an outlet in the bottom center of the fuselage below the rear cabin area.

An optional overhead ventilating system with outlets over each seat is also available. An additional option to aid in fresh air circulation on models without air conditioning is a cabin air blower to force air through the overhead vent system. This blower is operated by a fan switch with four positions - OFF, LOW, MED, and HIGH. The switch is located on the right side of the instrument panel with the heater and defroster controls.

7.25 CABIN FEATURES

For ease of entry and exit, and for pilot-passenger comfort, the front seats are adjustable fore and aft. The right front seat tilts forward to allow easy entry to the rear seats (if installed) and baggage area. The cabin interior includes a pilot storm window, ash trays and armrests on each front seat, two map pockets and pockets on the backs of the front seats.

The front seats can be equipped with optional headrests and optional vertical adjustment.

Both front and rear seats (when installed), are equipped with fixed shoulder harnesses. Optional shoulder harness with inertia reels are available for all installed seats. A check of the inertia reel mechanism can be made by pulling sharply on the strap and checking that the reel will lock in place under sudden stress. This locking feature prevents the strap from extending and holds the occupant in place. Under normal movement the strap will extend and retract as required. Shoulder harnesses should be routinely worn during takeoff, landing and whenever an inflight emergency situation occurs.

7.27 BAGGAGE AREA

A 24 cubic foot baggage area, accessible from the cabin, is located behind the seats. Maximum capacity is 50 pounds. Tiedown straps are available and they should be used at all times.

NOTE

It is the pilot's responsibility to be sure that when baggage is loaded the aircraft C.G. falls within the allowable C.G. range. (See Weight and Balance Section.)

7.29 STALL WARNING

An approaching stall is indicated by an audible alarm located behind the instrument panel. The indicator activates between five and ten knots above stall speed.

7.31 FINISH

All exterior surfaces are primed with etching primer and finished with acrylic lacquer. To keep the finish attractive, economy size spray cans of touch-up paint are available from Piper Dealers.

An optional polyurethane finish is available.

7.33 *PIPER EXTERNAL POWER

An optional starting installation known as Piper External Power (PEP) is accessible through a receptacle located on the right side of the fuselage, forward of the wing. An external battery can be connected to the socket, thus allowing the operator to crank the engine without having to gain access to the airplane's battery. Instructions on a placard located on the cover of the receptacle should be followed before using the external power. For instructions on the use of the PEP see ENGINE START WITH EXTERNAL POWER in Section 4 - Normal Procedures.

7.35 *EMERGENCY LOCATOR TRANSMITTER

The Emergency Locator Transmitter (ELT), when installed, is located in the aft portion of the fuselage just below the stabilator leading edge and is accessible through a plate on the right side of the fuselage. This plate is attached with slotted-head nylon screws for ease of removal; these screws may be readily removed with a variety of common items such as a dime, a key, a knife blade, etc. If there are no tools available in an emergency, the screw heads may be broken off by any means. The ELT meets the requirements of FAR 91.52.

A battery replacement date is marked on the transmitter to comply with FAA regulations, the battery must be replaced on or before this date. The battery must also be replaced if the transmitter has been used in an emergency situation or, if the accumulated test time exceeds one hour, or if the unit has been inadvertently activated for an undetermined time period.

NOTE

If for any reason a test transmission is necessary, the test transmission should be conducted only in the first five minutes of any hour and limited to three audio sweeps. If the tests must be made at any other time, the tests should be coordinated with the nearest FAA tower or flight service station.

*Optional equipment

ISSUED: SEPTEMBER 9, 1988

**REPORT: VB-1360
7-23**

NARCO ELT 10 OPERATION

On the ELT unit itself is a three position switch placarded ON, OFF and ARM. The ARM position sets the ELT so that it will transmit after impact and will continue to transmit until its battery is drained. The ARM position is selected when the ELT is installed in the airplane, and it should remain in that position.

To use the ELT as a portable unit in an emergency, remove the cover and unlatch the unit from its mounting base. The antenna cable is disconnected by a left quarter-turn of the knurled nut and a pull. A sharp tug on the two small wires will break them loose. Deploy the self-contained antenna by pulling the plastic tab marked PULL FULLY TO EXTEND ANTENNA. Move the switch to ON to activate the transmitter.

In the event the transmitter is activated by an impact, it can only be turned off by moving the switch on the ELT unit to OFF. Normal operation can then be restored by pressing the small clear plastic reset button located on the top of the front face of the ELT and then moving the switch to ARM.

A pilot's remote switch located on the left side panel is provided to allow the transmitter to be turned on from inside the cabin. The pilot's remote switch is placarded ON and ARMED. The switch is normally in the ARMED position. Moving the switch to ON will activate the transmitter. Moving the switch back to the ARMED position will turn off the transmitter only if the impact switch has not been activated.

The ELT should be checked to make certain the unit has not been activated during the ground check. Check by selecting 121.50 MHz on an operating receiver. If there is an oscillating chirping sound, the ELT may have been activated and should be turned off immediately. This requires removal of the access cover and moving the switch to OFF, then press the reset button and return the switch to ARM. Recheck with the receiver to ascertain that the transmitter is silent.

NARCO ELT 910 OPERATION

On the ELT unit itself is a three position switch placarded ON, OFF and ARM. The ARM position sets the ELT so that it will transmit after impact and will continue to transmit until its battery is drained. The ARM position is selected when the ELT is installed in the airplane and it should remain in that position.

A pilot's remote switch, placarded ON and ARM, is located on the left side panel to allow the transmitter to be armed or turned on from inside the cabin. The switch is normally in the ARM position. Moving the switch to ON will activate the transmitter. A warning light, located above the remote switch, will blink continuously whenever the ELT is activated.

NOTE

The warning light will not blink if the ELT is activated by an incident that also results in severance of the airplane's power supply lines.

Should the ELT be activated inadvertently it can be reset by either positioning the remote switch to the ON position for two seconds, and then relocating it to the ARM position, or by setting the switch on the ELT to OFF and then back to ARM.

In the event the transmitter is activated by an impact, it can be turned off by moving the ELT switch OFF. Normal operation can then be restored by resetting the switch to ARM. It may also be turned off and reset by positioning the remote switch to the ON position for two seconds, and then to the ARM position.

The transmitter can be activated manually at any time by placing either the remote switch or the ELT switch to the ON position.

The ELT should be checked during postflight to make certain the unit has not been activated. Check by selecting 121.50 MHz on an operating receiver. If a downward sweeping audio tone is heard the ELT may have been activated. Set the remote switch to ON. If there is no change in the tone it is probably you. Setting the remote switch back to ARM will automatically reset the ELT.

THIS PAGE INTENTIONALLY LEFT BLANK

7.37 *AIR CONDITIONING

The air conditioning system is a recirculating air system. The major items include evaporator, condenser, compressor, blower, switches and temperature controls.

The evaporator is located behind the left rear side of the aft close out panel. This cools the air that is used for air conditioning.

The condenser is mounted on a retractable scoop located on the bottom of the fuselage and to the rear of the baggage compartment area. The scoop extends when the air conditioner is ON and retracts to a flush position when the system is OFF.

The compressor is mounted on the forward right underside of the engine. It has an electric clutch which automatically engages or disengages the compressor to the belt drive system of the compressor.

An electrical blower is mounted on the aft side of the rear cabin panel. Air from the cabin area is drawn through the evaporator by the blower and distributed through an overhead duct to individual outlets located adjacent to each occupant.

The switches and temperature control are located on the lower right side of the instrument panel in the climate control center panel. The temperature control regulates the desired temperature of the cabin. Turn the control clockwise for increased cooling, counterclockwise for decreased cooling.

Located inboard of the temperature control is the fan speed switch and the air conditioning ON-OFF switch. The fan can be operated independently of the air conditioning. However, it must be on for air conditioner operation. Turning either switch off will disengage the compressor clutch and retract the condenser door. Cooling air should be felt within one minute after the air conditioner is turned on.

NOTE

If the system is not operating in 5 minutes, turn the system OFF until the fault is corrected.

*Optional equipment

ISSUED: SEPTEMBER 9, 1988

REPORT: VB-1360
7-25

The FAN switch allows operation of the fan with the air conditioner turned OFF to aid cabin air circulation if desired. A LOW, MED or HIGH flow of air can be selected to the air conditioner outlets located in the overhead duct. The outlets can be adjusted or turned off by each occupant to regulate individual cooling effect.

The DOOR OPEN indicator light is located to the left of the radio stack in front of the pilot. The light illuminates whenever the condenser door is open and remains on until the door is closed.

A circuit breaker located on the circuit breaker panel protects the air conditioning electrical system.

Whenever the throttle is in the full throttle position, it actuates a micro switch which disengages the compressor and retracts the scoop. This is done to obtain maximum power and maximum rate of climb. The fan continues to operate and the air will remain cool for approximately one minute. When the throttle is retarded approximately $\frac{1}{4}$ inch, the clutch will engage and the scoop will extend, again supplying cool, dry air.

7.39 *CARBURETOR ICE DETECTION SYSTEM

A carburetor ice detection system is available as optional equipment.

The system consists of a control box mounted on the instrument panel, a probe sensor mounted in the carburetor and a red warning light to indicate the presence of ice in the carburetor. If ice is present apply full carburetor heat. Refer to Carburetor Icing, Section 3, Emergency Procedures. To adjust the system for critical ice detection, first turn on the airplanes master switch and then turn on the ice detection unit. Turn the sensitivity knob fully counterclockwise causing the carb. ice light to come on. Now rotate the sensitivity knob back (clockwise) until the ice light just goes out. This establishes the critical setting.

WARNING

This instrument is approved as optional equipment only and Flight Operations should not be predicated on its use.

*Optional equipment

TABLE OF CONTENTS

SECTION 8

AIRPLANE HANDLING, SERVICING AND MAINTENANCE

Paragraph No.		Page No.
8.1	General	8-1
8.3	Airplane Inspection Periods	8-2
8.5	Preventive Maintenance	8-3
8.7	Airplane Alterations	8-4
8.9	Ground Handling	8-5
8.11	Engine Air Filter	8-7
8.13	Brake Service	8-8
8.15	Landing Gear Service	8-8
8.17	Propeller Service	8-10
8.19	Oil Requirements	8-11
8.21	Fuel System	8-11
8.23	Tire Inflation	8-14
8.25	Battery Service	8-14
8.27	Cleaning	8-15
8.29	Cold Weather Operation	8-18



SECTION 8

AIRPLANE HANDLING, SERVICING AND MAINTENANCE

8.1 GENERAL

This section provides general guidelines relating to the handling, servicing, and maintenance of the Cadet. For complete maintenance instructions, refer to the PA-28-161 Service Manual.

Every owner should stay in close contact with an authorized Piper Service Center or Piper's Customer Services Department to obtain the latest information pertaining to their airplane, and to avail themselves of Piper Aircraft's support systems.

Piper Aircraft Corporation takes a continuing interest in having owners get the most efficient use from their aircraft and keeping it in the best mechanical condition. Consequently, Piper Aircraft, from time to time, issues service releases including Service Bulletins, Service Letters, Service Spares Letters, and others relating to the airplane.

Service Bulletins are of special importance and Piper considers compliance mandatory. These are sent directly to the latest FAA-registered owners in the United States (U.S.) and Piper Service Centers worldwide. Depending on the nature of the release, material and labor allowances may apply. This information is provided to all authorized Piper Service Centers.

Service Letters deal with product improvements and servicing techniques pertaining to the airplane. They are sent to Piper Service Centers and, if necessary, to the latest FAA-registered owners in the U.S. Owners should give careful attention to Service Letter information.

Service Spares Letters offer improved parts, kits, and optional equipment which were not available originally, and which may be of interest to the owner.

Piper Aircraft Corporation offers a subscription service for Service Bulletins, Service Letters, and Service Spares Letters. This service is available to interested persons, such as owners, pilots, and mechanics at a nominal fee, and may be obtained through an authorized Piper Service Center or Piper's Customer Services Department.

Maintenance manuals, parts catalogs, and revisions to both, are available from your Piper Service Centers or Piper's Customer Services Department.

Any correspondence regarding the airplane should include the airplane model and serial number to ensure proper response.

8.3 AIRPLANE INSPECTION PERIODS

Piper Aircraft Corporation has developed inspection items and required inspection intervals (i.e.: 50, 100, 500, and 1000 hours) for the specific model aircraft. Appropriate forms are contained in the applicable Piper Service/Maintenance Manual, and should be complied with by a properly trained, knowledgeable, and qualified mechanic at a Piper Authorized Service Center or a reputable repair shop. Piper Aircraft Corporation cannot accept responsibility for the continued airworthiness or any aircraft not maintained to these standards, and/or not brought into compliance with applicable Service Bulletins issued by Piper Aircraft Corporation, instructions issued by the engine, propeller, or accessory manufacturers, or Airworthiness Directives issued by the FAA.

A programmed inspection, approved by the Federal Aviation Administration (FAA), is also available to the owner. This involves routine and detailed inspections to allow maximum utilization of the airplane. Maintenance inspection costs are reduced, and the maximum standard of continued airworthiness is maintained. Complete details are available from Piper Aircraft Corporation.

In addition, but in conjunction with the above, the FAA requires periodic inspections on all aircraft to keep the Airworthiness Certificate in effect. The owner is responsible for assuring compliance with these inspection requirements and for maintaining proper documentation in logbooks and/or maintenance records.

A spectographic analysis of the engine oil is available from several sources. This inspection, if performed properly, provides a good check of the internal condition of the engine. To be accurate, induction air filters must be cleaned or changed regularly, and oil samples must be taken and sent in at regular intervals.

8.5 PREVENTIVE MAINTENANCE

The holder of a pilot certificate issued under Federal Aviation Regulation (FAR) Part 61 may perform certain preventive maintenance as defined in the FAR's. This maintenance may be performed only on an aircraft which the pilot owns and operates, and which is not used in air carrier or air taxi/commercial operations service.

All other aircraft maintenance must be accomplished by a person or facility appropriately certificated by the Federal Aviation Administration (FAA) to perform that work.

Anytime maintenance is accomplished, an entry must be made in the appropriate aircraft maintenance records. The entry shall include:

- (a) The date the work was accomplished.
- (b) Description of the work.
- (c) Number of hours on the aircraft.
- (d) The certificate number of pilot performing the work.
- (e) Signature of the individual doing the work.

8.7 AIRPLANE ALTERATIONS

If the owner desires to have his aircraft modified, he must obtain FAA approval for the alteration. Major alterations accomplished in accordance with Advisory Circular 43.13-2, when performed by an A & P mechanic, may be approved by the local FAA office. Major alterations to the basic airframe or systems not covered by AC 43.13-2 require a Supplemental Type Certificate.

The owner or pilot is required to ascertain that the following Aircraft Papers are in order and in the aircraft.

- (a) To be displayed in the aircraft at all times:
 - (1) Aircraft Airworthiness Certificate Form FAA-8100-2.
 - (2) Aircraft Registration Certificate Form FAA-8050-3.
 - (3) Aircraft Radio Station License if transmitters are installed.

- (b) To be carried in the aircraft at all times:
 - (1) Pilot's Operating Handbook.
 - (2) Weight and Balance data plus a copy of the latest Repair and Alteration Form FAA-337, if applicable.
 - (3) Aircraft equipment list.

Although the aircraft and engine logbooks are not required to be in the aircraft, they should be made available upon request. Logbooks should be complete and up to date. Good records will reduce maintenance cost by giving the mechanic information about what has or has not been accomplished.

8.9 GROUND HANDLING

(a) Towing

The airplane may be moved on the ground by the use of the nose wheel steering bar that is stowed in the cabin, or by power equipment that will not damage or excessively strain the nose gear steering assembly. Towing lugs are incorporated as part of the nose gear fork.

CAUTIONS

When towing with power equipment, do not turn the nose gear beyond its steering radius in either direction, as this will result in damage to the nose gear and steering mechanism.

Do not tow the airplane when the controls are secured.

In the event towing lines are necessary, ropes should be attached to both main gear struts as high up on the tubes as possible. Lines should be long enough to clear the nose and/or tail by not less than fifteen feet, and a qualified person should ride in the pilot's seat to maintain control by use of the brakes.

(b) Taxiing

Before attempting to taxi the airplane, ground personnel should be instructed and approved by a qualified person authorized by the owner. Engine starting and shut-down procedures as well as taxi techniques should be covered. When it is ascertained that the propeller back blast and taxi areas are clear, power should be applied to start the taxi roll, and the following checks should be performed:

- (1) Taxi a few feet forward and apply the brakes to determine their effectiveness.
- (2) While taxiing, make slight turns to ascertain the effectiveness of the steering.
- (3) Observe wing clearance when taxiing near buildings or other stationary objects. If possible, station an observer outside the airplane.

- (4) When taxiing over uneven ground, avoid holes and ruts.
- (5) Do not operate the engine at high rpm when running up or taxiing over ground containing loose stones, gravel, or any loose material that may cause damage to the propeller blades.

(c) Parking

When parking the airplane, be sure that it is sufficiently protected from adverse weather conditions and that it presents no danger to other aircraft. When parking the airplane for any length of time or overnight, it is suggested that it be moored securely.

- (1) To park the airplane, head it into the wind if possible.
- (2) Set the parking brake by pulling back on the brake lever and depressing the knob on the handle. To release the parking brake, pull back on the handle until the catch disengages; then allow the handle to swing forward.

CAUTION

Care should be taken when setting brakes that are overheated or during cold weather when accumulated moisture may freeze a brake.

- (3) Aileron and stabilator controls should be secured with the front seat belt and chocks used to properly block the wheels.

(d) Mooring

The airplane should be moored for immovability, security and protection. The following procedures should be used for the proper mooring of the airplane:

- (1) Head the airplane into the wind if possible.
- (2) Retract the flaps.
- (3) Immobilize the ailerons and stabilator by looping the seat belt through the control wheel and pulling it snug.
- (4) Block the wheels.

(5) Secure tiedown ropes to the wing tiedown rings and to the tail skid at approximately 45-degree angles to the ground. When using rope of non-synthetic material, leave sufficient slack to avoid damage to the airplane should the ropes contract.

CAUTION

Use bowline knots, square knots or locked slip knots. Do not use plain slip knots.

NOTE

Additional preparations for high winds include using tiedown ropes from the landing gear forks and securing the rudder.

- (6) Install a pitot head cover if available. Be sure to remove the pitot head cover before flight.
- (7) Cabin door should be locked when the airplane is unattended.

8.11 ENGINE AIR FILTER

The wet-type polyurethane foam air filter must be inspected at least once every fifty hours. Under extremely adverse operating conditions, it may be necessary to inspect the filter more frequently. The filter is disposable and inexpensive and a spare should be kept on hand for a rapid replacement.

(a) Removal Of Engine Air Filter

The filter is located in the lower right front of the engine compartment and may be removed by the following procedure:

- (1) Open the right side of the engine cowling.
- (2) Loosen each of the four quarter-turn fasteners securing the air filter cover.
- (3) Separate the cover and remove the filter.
- (4) Inspect the filter. If it is excessively dirty or shows any damage, replace it immediately.

(b) Installation Of Engine Air Filter

When replacing the filter, install the filter in the reverse order of removal.

8.13 BRAKE SERVICE

The brake system is filled with MIL-H-5606 (petroleum base) hydraulic brake fluid. The fluid level should be checked periodically or at every 50-hour inspection and replenished when necessary. The brake reservoir is located on the fire wall in the engine compartment. If the entire system must be refilled, fill with fluid under pressure from the brake end of the system. This will eliminate air from the system.

No adjustment of the brake clearances is necessary. If after extended service brake blocks become excessively worn, they should be replaced with new segments.

8.15 LANDING GEAR SERVICE

The main landing gears use 6.00 x 6 wheels and the nose gear carries a 5.00 x 5 wheel. All three tires are four-ply rating, type III tires with tubes. (Refer to paragraph 8.23).

Wheels are removed by taking off the hub cap, cotter pin, axle nut, and the two bolts holding the brake segment in place. Mark tire and wheel for reinstallation; then dismount by deflating the tire, removing the three through-bolts from the wheel and separating the wheel halves.

Landing gear oleos should be serviced according to the instructions on the units. The main oleos should be extended under normal static load until 4.50 +/- 0.25 inches of oleo piston tube is exposed, and the nose gear should show 3.25 +/- 0.25 inches. Should the strut exposure be below that required, it should be determined whether air or oil is required by first raising the airplane on jacks. Depress the valve core to allow air to escape from the strut housing chamber. Remove the filler plug and slowly raise the strut to full compression. If the strut has sufficient fluid, it will be visible up to the bottom of the filler plug hole and will then require only proper inflation.

1. BRAKE RESERVOIR
2. RIGHT BRAKE AND RUDDER PEDAL
3. LEFT BRAKE AND RUDDER PEDAL
4. RIGHT BRAKE CYLINDER
5. LEFT BRAKE CYLINDER
6. BRAKE HANDLE
7. HANDLE RELEASE BUTTON
8. LINE INLET
9. CLEVIS PIN
10. MASTER CYLINDER ASSEMBLY
11. BOLT ASSEMBLY
12. TORQUE TUBE
13. COPILOT'S RIGHT BRAKE AND RUDDER PEDAL
14. COPILOT'S LEFT BRAKE AND RUDDER PEDAL

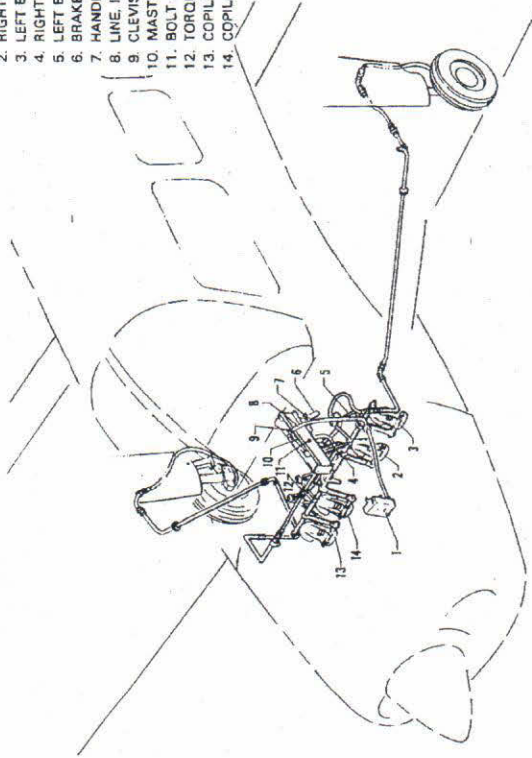

BRAKE SYSTEM
Figure 8-1

ISSUED: SEPTEMBER 9, 1988

REPORT: VB-1360
8-9

Should hydraulic fluid be below the bottom of the filler plug hole, fluid should be added. Replace the plug with valve core removed; attach a clear plastic hose to the valve stem of the filler plug and submerge the other end in a container of hydraulic fluid. Fully compress and extend the strut several times, thus drawing fluid from the container and expelling air from the strut chamber. To allow fluid to enter the bottom chamber of the main gear strut housing, the torque link assembly must be disconnected to let the strut be extended a minimum of 10 inches (the nose gear torque links need not be disconnected). Do not allow the strut to extend more than 12 inches. When air bubbles cease to flow through the hose, compress the strut fully and again check fluid level. Reinstall the valve core and filler plug, and the main gear torque links, if disconnected.

With fluid in the strut housing at the correct level, attach a strut pump to the air valve and with the airplane on the ground, inflate the oleo strut to the correct height.

In jacking the aircraft for landing gear or other service, two hydraulic jacks and a tail stand should be used. At least 250 pounds of ballast should be placed on the base of the tail stand before the airplane is jacked up. The hydraulic jacks should be placed under the jack points on the bottom of the wing and the airplane jacked up until the tail skid is at the right height to attach the tail stand. After the tail stand is attached and the ballast added, jacking may be continued until the airplane is at the height desired.

8.17 PROPELLER SERVICE

The spinner and backing plate should be frequently cleaned and inspected for cracks. Before each flight the propeller should be inspected for nicks, scratches, and corrosion. If found, they should be repaired as soon as possible by a rated mechanic, since a nick or scratch causes an area of increased stress which can lead to serious cracks or the loss of a propeller tip. The back face of the blades should be painted when necessary with flat black paint to retard glare. To prevent corrosion, the surface should be cleaned and waxed periodically.

8.19 OIL REQUIREMENTS

The oil capacity of the engine is 8 quarts, and the minimum safe quantity is 2 quarts. It is recommended that engine oil be drained and renewed every 50 hours, or sooner under unfavorable conditions. Full flow cartridge type oil filters should be replaced each 50 hours of operation. The interval between oil and oil filter change should not exceed a total of four (4) months. The following seasonal aviation oil grades are recommended for the seasonal ambient temperature ranges:

Average Ambient Air Temperature	MIL-L-6082B Mineral SAE Grade	MIL-L-22851 Ashless Dispersant SAE Grades
All Temperatures	--	15W-50 or 20W-50
Above 80°F	60	60
Above 60°F	50	40 or 50
30°F to 90°F	40	40
0°F to 70°F	30	30, 40 or 20W-40
0°F to 90°F	20W50	20W50 or 15W50
Below 10°F	20	30 or 20W-30

When operating temperatures overlap indicated ranges, use the lighter grade oil.

NOTE

Refer to the latest issue of Lycoming Service Instruction 1014 (Lubricating Oil Recommendations) for further information.

8.21 FUEL SYSTEM

(a) Servicing Fuel System

At every 50-hour inspection, the fuel screens in the strainer, in the electric fuel pump, and at the carburetor inlet must be cleaned.

(b) Fuel Requirements (AVGAS ONLY)

The minimum aviation grade fuel for the PA-28-161 is 100. Since the use of lower grades can cause serious engine damage in a short period of time, the engine warranty is invalidated by the use of lower octanes.

Whenever 100 or 100LL grade fuel is not available, commercial grade 100/130 should be used. (See Fuel Grade Comparison Chart). Refer to the latest issue of Lycoming Service Instruction No. 1070 for additional information.

A summary of the current grades as well as the previous fuel designations is shown in the following chart:

FUEL GRADE COMPARISON CHART

Previous Commercial Fuel Grades (ASTM-D910)			Current Commercial Fuel Grades (ASTM-D910-75)			Current Military Fuel Grades (MIL-G-5572F)		
Grade	Color	Max. TEL ml/U.S. gal	Grade	Color	Max. TEL ml/U.S. gal	Grade	Color	Max. TEL ml/U.S. gal
80/87	red	0.5	80	red	0.5	80/87	red	0.5
91/96	blue	2.0	*100LL	blue	2.0	100/130	blue	2.0
100/130	green	3.0	100	green	**3.0	none	none	none
115/145	purple	4.6	none	none	none	115/145	purple	4.6

* -Grade 100LL fuel in some overseas countries is currently colored green and designated as 100L.

** -Commercial fuel grade 100 and grade 100/130 having TEL content of up to 4 ml/U.S. gallon are approved for use in all engines certificated for use with grade 100/130 fuel.

The operation of the aircraft is approved with an anti-icing additive in the fuel. When anti-icing additive is used, it must meet the specification MIL-I-27686, must be uniformly blended with the fuel while refueling, must not exceed 0.15% by volume of the refueled quantity, and to ensure its effectiveness should be blended at not less than 0.10% by volume. One and one half liquid ozs. per ten gallons of fuel would fall within this range. A blender supplied by the additive manufacturer should be used. Except for the information contained in this section, the manufacturer's mixing or blending instructions should be carefully followed.

CAUTIONS

Assure that the additive is directed into the flowing fuel stream. The additive flow should start after and stop before the fuel flow. Do not permit the concentrated additive to come in contact with the aircraft painted surfaces or the interior surfaces of the tanks.

Some fuels have anti-icing additives pre-blended in the fuel at the refinery, so no further blending should be performed.

Fuel additive cannot be used as a substitute for preflight draining of the fuel system drains.

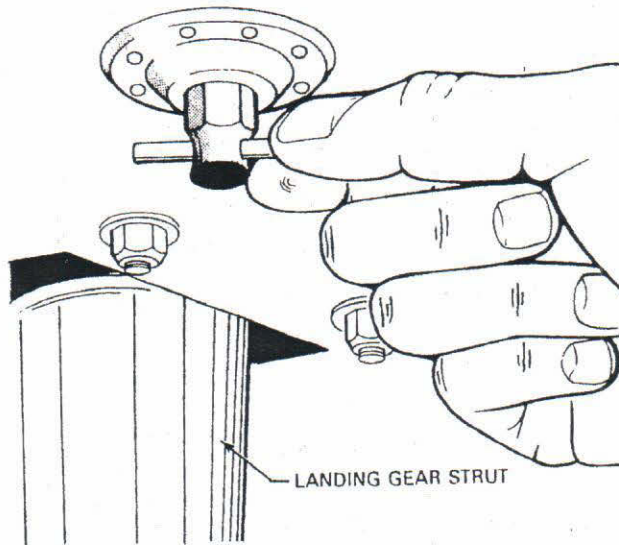

FUEL DRAIN
Figure 8-3

(c) Filling Fuel Tanks

Observe all required precautions for handling gasoline. Fuel is stored in two twenty-five gallon (24 usable) tanks.

(d) Draining Fuel Strainer, Sumps and Lines

The fuel system sumps and strainer should be drained daily prior to the first flight and after refueling to avoid the accumulation of contaminants such as water or sediment and for proper fuel. Each fuel tank is equipped with an individual quick drain located at the lower inboard rear corner of the tank. The fuel strainer is equipped with a quick drain located on the front lower corner of the fire wall. Each of the fuel tank sumps should be drained first. Then the fuel strainer should be drained twice, once with the fuel selector valve on each tank. Each time fuel is drained, sufficient fuel should be allowed to flow to ensure removal of contaminants. This fuel should be col-

lected in a suitable container, examined for contaminants, proper fuel and then discarded.

CAUTIONS

When draining any amount of fuel, care should be taken to ensure that no fire hazard exists before starting the engine.

After draining, each quick drain should be checked to make sure it has closed completely and is not leaking.

(e) Draining Fuel System

The bulk of the fuel may be drained from the system by opening the valve on the bottom of the wing at the inboard end of each fuel tank. Push up on the arms of the drain valve and turn counterclockwise to hold the drain open. The remaining fuel in the system may be drained through the filter bowl. Any individual tank may be drained by closing the selector valve and then draining the desired tank.

8.23 TIRE INFLATION

For maximum tire service, keep them inflated to the proper pressures; 30 psi for the nose gear and 24 psi for the main gear. All wheels and tires are balanced before original installation, and the relationship of tire, tube and wheel should be maintained upon reinstallation. Unbalanced wheels can cause extreme vibration in the landing gear; therefore, in the installation of new components, it may be necessary to rebalance the wheels with the tires mounted. When checking tire pressure, examine the tires for wear, cuts, bruises, and slippage.

8.25 BATTERY SERVICE

The 12 volt battery is installed in a covered box mounted on the forward right face of the firewall. To gain access, raise the upper right cowl and remove the battery box cover. The battery box has a drain tube that is normally closed off with a cap, which should be opened occasionally to drain off any accumulation of liquid.

The battery should be checked for proper fluid level. DO NOT fill the battery above the baffle plates. DO NOT fill the battery with acid; use only water. A hydrometer check will determine the percent of charge in the battery.

If the battery is not up to charge, recharge starting at a 4 amp rate and finishing with a 2 amp rate. Quick charges are not recommended.

8.27 CLEANING

(a) Cleaning Engine Compartment

Before cleaning the engine compartment, place a strip of tape on the magneto vents to prevent any solvent from entering these units.

- (1) Place a large pan under the engine to catch waste.
- (2) With the engine cowling removed, spray or brush the engine with solvent or a mixture of solvent and degreaser. In order to remove especially heavy dirt and grease deposits, it may be necessary to brush areas that were sprayed.

CAUTION

Do not spray solvent into the alternator, vacuum pump, starter, or air intakes.

- (3) Allow the solvent to remain on the engine from five to ten minutes. Then rinse the engine clean with additional solvent and allow it to dry.

CAUTION

Do not operate the engine until excess solvent has evaporated or otherwise been removed.

- (4) Remove the protective tape from the magnetos.
- (5) Lubricate the controls, bearing surfaces, etc., in accordance with the Lubrication Chart in the PA-28-161 Service Manual.

(b) Cleaning Landing Gear

Before cleaning the landing gear, place a plastic cover or similar material over the wheel and brake assembly.

- (1) Place a pan under the gear to catch waste.
- (2) Spray or brush the gear area with solvent or a mixture of solvent and degreaser, as desired. Where heavy grease and dirt deposits have collected, it may be necessary to brush areas that were sprayed, in order to clean them.
- (3) Allow the solvent to remain on the gear from five to ten minutes. Then rinse the gear with additional solvent and allow to dry.
- (4) Remove the cover from the wheel and remove the catch pan.
- (5) Lubricate the gear in accordance with the Lubrication Chart in the PA-28-161 Service Manual.

(c) Cleaning Exterior Surfaces

The airplane should be washed with a mild soap and water. Harsh abrasives or alkaline soaps or detergents could make scratches on painted or plastic surfaces or could cause corrosion of metal. Cover areas where cleaning solution could cause damage. To wash the airplane, use the following procedure:

- (1) Flush away loose dirt with water.
- (2) Apply cleaning solution with a soft cloth, a sponge or a soft bristle brush.
- (3) To remove exhaust stains, allow the solution to remain on the surface longer.
- (4) To remove stubborn oil and grease, use a cloth dampened with naphtha.
- (5) Rinse all surfaces thoroughly.
- (6) Any good automotive wax may be used to preserve painted surfaces. Soft cleaning cloths or a chamois should be used to prevent scratches when cleaning or polishing. A heavier coating of wax on the leading surfaces will reduce the abrasion problems in these areas.

(d) Cleaning Windshield and Windows

- (1) Remove dirt, mud and other loose particles from exterior surfaces with clean water.

- (2) Wash with mild soap and warm water or with aircraft plastic cleaner. Use a soft cloth or sponge in a straight back and forth motion. Do not rub harshly.
- (3) Remove oil and grease with a cloth moistened with kerosene.

CAUTION

Do not use gasoline, alcohol, benzene, carbon tetrachloride, thinner, acetone, or window cleaning sprays.

- (4) After cleaning plastic surfaces, apply a thin coat of hard polishing wax. Rub lightly with a soft cloth. Do not use a circular motion.
- (5) A severe scratch or mar in plastic can be removed by rubbing out the scratch with jeweler's rouge. Smooth both sides and apply wax.

(e) Cleaning Headliner, Side Panels and Seats

- (1) Clean headliner, side panels, and seats with a stiff bristle brush, and vacuum where necessary.
- (2) Soiled upholstery, except leather, may be cleaned with a good upholstery cleaner suitable for the material. Carefully follow the manufacturer's instructions. Avoid soaking or harsh rubbing.

CAUTION

Solvent cleaners require adequate ventilation.

- (3) Leather should be cleaned with saddle soap or a mild hand soap and water.

(f) Cleaning Carpets

To clean carpets, first remove loose dirt with a whisk broom or vacuum. For soiled spots and stubborn stains use a nonflammable dry cleaning fluid. Floor carpets may be removed and cleaned like any household carpet.

8.29 COLD WEATHER OPERATION

For cold weather operation a winterization plate is installed on the inlet opening of the oil cooler. This plate should be installed whenever the ambient temperature reaches 50°F or less. The plate should be removed and stored in the cockpit when the ambient temperature exceeds 50°F.

It is recommended that an optional Engine Breather Tube Winterization Kit be installed for cold weather operation. This kit is available through a Piper Service Center or Piper's Customer Services Department.

TABLE OF CONTENTS

SECTION 9

SUPPLEMENTS

Paragraph/Supplement No.		Page No.
9.1	General	9-1
1	Piper Electric Pitch Trim (4 pages)	9-3
2	Air Conditioning Installation (4 pages)	9-7
3	KAP 100 Series Flight Control System (20 pages)	9-11
4	Auxiliary Vacuum System (6 pages)	9-31

Handwritten text, likely bleed-through from the reverse side of the page. The text is extremely faint and illegible due to the low contrast and resolution of the scan. It appears to be several lines of a letter or document, but no specific words or phrases can be discerned.

**SECTION 9
SUPPLEMENTS**

9.1 GENERAL

This section provides information in the form of Supplements which are necessary for efficient operation of the airplane when equipped with one or more of the various optional systems and equipment not provided with the standard airplane.

All of the Supplements provided by this section are FAA Approved and consecutively numbered as a permanent part of this Handbook. The information contained in each Supplement applies only when the related equipment is installed in the airplane.

THIS PAGE INTENTIONALLY LEFT BLANK

PILOT'S OPERATING HANDBOOK
AND
FAA APPROVED AIRPLANE FLIGHT MANUAL

SUPPLEMENT NO. 1
FOR
PIPER ELECTRIC PITCH TRIM

This supplement must be attached to the Pilot's Operating Handbook and FAA Approved Airplane Flight Manual when the Piper Electric Pitch Trim System is installed in accordance with Piper Drawing No. 67496-7. The information contained herein supplements or supersedes the basic Pilot's Operating Handbook and FAA Approved Airplane Flight Manual only in those areas listed herein. For limitations, procedures and performance information not contained in this supplement, consult the basic Pilot's Operating Handbook and FAA Approved Airplane Flight Manual.

FAA APPROVED

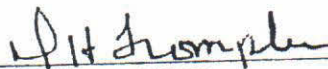
D. H. TROMPLER
D.O.A. NO. SO-1
PIPER AIRCRAFT CORPORATION
VERO BEACH, FLORIDA

DATE OF APPROVAL October 7, 1988

ISSUED: SEPTEMBER 9, 1988

REPORT: VB-1360
1 of 4, 9-3

SECTION 1 - GENERAL

This supplement supplies information necessary for the operation of the airplane when the optional Piper Electric Pitch Trim is installed. The information contained within this supplement is to be used in conjunction with the complete handbook.

SECTION 2 - LIMITATIONS

No change.

SECTION 3 - EMERGENCY PROCEDURES

- (a) In case of malfunction, disconnect electric pitch trim by activating pitch trim switch on pilot's control yoke to OFF position.
- (b) In an emergency, electric pitch trim may be overpowered using manual pitch trim.
- (c) In cruise configuration, malfunction results in 10° pitch change and 200 ft altitude variation.
- (d) In approach configuration, a malfunction can result in a 5° pitch change and 50 ft altitude loss.

SECTION 4 - NORMAL PROCEDURES

The electric trim system may be turned ON and OFF by a switch located on the left horn of the pilot's control yoke adjacent to the trim control switch. The pitch trim may be changed when the electric trim system is turned on either by moving the manual pitch trim control wheel or by operating the trim control switch on the pilot's control yoke.

SECTION 5 - PERFORMANCE

No change.

SECTION 6 - WEIGHT AND BALANCE

Factory installed optional equipment is included in the licensed weight and balance data in Section 6 of the basic Pilot's Operating Handbook.

SECTION 7 - DESCRIPTION AND OPERATION

No change.

THIS PAGE INTENTIONALLY LEFT BLANK

PILOT'S OPERATING HANDBOOK
AND
FAA APPROVED AIRPLANE FLIGHT MANUAL
SUPPLEMENT NO. 2
FOR
AIR CONDITIONING INSTALLATION

This supplement must be attached to the Pilot's Operating Handbook and FAA Approved Airplane Flight Manual when the Air Conditioning System is installed in accordance with Piper Drawing No. 99575-6. The information contained herein supplements or supersedes the basic Pilot's Operating Handbook and FAA Approved Airplane Flight Manual only in those areas listed herein. For limitations, procedures and performance information not contained in this supplement, consult the basic Pilot's Operating Handbook and FAA Approved Airplane Flight Manual.

FAA APPROVED

D. H. Trompler

D. H. TROMPLER
D.O.A. NO. SO-1
PIPER AIRCRAFT CORPORATION
VERO BEACH, FLORIDA

DATE OF APPROVAL October 7, 1988

ISSUED: SEPTEMBER 9, 1988

REPORT: VB-1360
1 of 4, 9-7

SECTION 1 - GENERAL

This supplement supplies information necessary for the efficient operation of the airplane when the optional air conditioning system is installed. The information contained within this supplement is to be used as described in conjunction with the complete handbook.

SECTION 2 - LIMITATIONS

- (a) To ensure maximum climb performance the air conditioner must be turned OFF manually prior to takeoff to disengage the compressor and retract the condenser door. Also the air conditioner must be turned OFF manually before the landing approach in preparation for a possible go-around.

(b) Placards

In full view of the pilot, in the area of the air conditioner controls when the air conditioner is installed:

**WARNING - AIR CONDITIONER MUST
BE OFF TO INSURE NORMAL TAKEOFF
CLIMB PERFORMANCE.**

In full view of the pilot, to the right of the tachometer (condenser door light):

AIR COND DOOR OPEN

SECTION 3 - EMERGENCY PROCEDURES

No change.

SECTION 4 - NORMAL PROCEDURES

Prior to takeoff, the air conditioner should be checked for proper operation as follows:

- (a) Check aircraft master switch ON.
- (b) Turn the air conditioner control switch to ON and the fan switch to one of the operating positions - the AIR COND DOOR OPEN warning light will turn on, thereby indicating proper air conditioner condenser door actuation.
- (c) Turn the air conditioner control switch to OFF - the AIR COND DOOR OPEN warning light will go out, thereby indicating the air conditioner condenser door is in the up position.
- (d) If the AIR COND DOOR OPEN light does not respond as specified above, an air conditioner system or indicator bulb malfunction is indicated and further investigation should be conducted prior to flight.

The above operational check may be performed during flight if an in flight failure is suspected.

The condenser door light is located on the pilot's instrument panel to the right of the tachometer. The door light illuminates when the door is open and is off when the door is closed.

SECTION 5 - PERFORMANCE

Operation of the air conditioner will cause slight decreases in cruise speed and range. Power from the engine is required to run the compressor, and the condenser door, when extended, causes a slight increase in drag. When the air conditioner is turned off there is normally no measurable difference in climb, cruise or range performance of the airplane.

NOTE

To insure maximum climb performance the air conditioner must be turned off manually before takeoff to disengage the compressor and retract the condenser door. Also the air conditioner must be turned off manually before the landing approach in preparation for a possible go-around.

Although the cruise speed and range are only slightly affected by the air conditioner operation, these changes should be considered in preflight planning. To be conservative, the following figures assume that the compressor is operating continuously while the airplane is airborne. This will be the case only in extremely hot weather.

- (a) The decrease in true airspeed is approximately 4 KTS at all power settings.
- (b) The decrease in range may be as much as 32 nautical miles for the 48 gallon capacity.

The climb performance is not compromised measurably with the air conditioner operating since the compressor is declutched and the condenser door is retracted, both automatically, when a full throttle position is selected. When the full throttle position is not used or in the event of a malfunction which would cause the compressor to operate and the condenser door to be extended, a decrease in rate of climb of as much as 100 fpm can be expected. Should a malfunction occur which prevents condenser door retraction when the compressor is turned off, a decrease in rate of climb of as much as 50 fpm can be expected.

SECTION 6 - WEIGHT AND BALANCE

Factory installed optional equipment is included in the licensed weight and balance data in Section 6 of the basic Pilot's Operating Handbook.

SECTION 7 - DESCRIPTION AND OPERATION

No change.

PILOT'S OPERATING HANDBOOK
AND
FAA APPROVED AIRPLANE FLIGHT MANUAL
SUPPLEMENT NO. 3
FOR
KING KAP 100 SERIES FLIGHT CONTROL SYSTEM

This supplement must be attached to the Pilot's Operating Handbook and FAA Approved Airplane Flight Manual when the King KAP 100 Series Flight Control System is installed in accordance with STC SA1565CE-D. The information contained herein supplements or supersedes the information in the basic Pilot's Operating Handbook and FAA Approved Airplane Flight Manual only in those areas listed herein. For limitations, procedures and performance information not contained in this supplement, consult the basic Pilot's Operating Handbook and FAA Approved Airplane Flight Manual.

FAA APPROVED

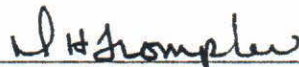

D. H. TROMPLER
D.O.A. NO. SO-1
PIPER AIRCRAFT CORPORATION
VERO BEACH, FLORIDA

DATE OF APPROVAL October 7, 1988

ISSUED: SEPTEMBER 9 1988

REPORT: YB-1360
1 of 20, 9-11

SECTION 1 - GENERAL

This supplement supplies information necessary for the operation of the airplane when the optional King KAP 100 Series Flight Control System is installed. The Flight Control System must be operated within the limitations herein specified. The information contained within this supplement is to be used in conjunction with the complete handbook.

This supplement has been FAA Approved as a permanent part of this handbook and must remain in this handbook at all times when the optional King KAP 100 Series Flight Control System is installed.

SECTION 2 - LIMITATIONS

The autopilot must be OFF during takeoff and landing.

SECTION 3 - EMERGENCY PROCEDURES

(a) SYSTEM WITH AUTOPILOT ONLY

- (1) In case of Autopilot malfunction: (accomplish items a. and b. simultaneously)
 - a. Airplane Control Wheel - GRASP FIRMLY and regain aircraft control.
 - b. AP ENG Button - PRESS to disengage autopilot.

(b) SYSTEMS WITH AUTOPILOT AND OPTIONAL MANUAL ELECTRIC TRIM

- (1) In case of Autopilot malfunction: (accomplish items a. and b. simultaneously)
 - a. Airplane Control Wheel - GRASP FIRMLY and regain aircraft control.
 - b. AP DISC/TRIM INTER Switch - PRESS.
- (2) In case of Manual Electric Trim malfunction:
 - a. AP DISC/TRIM INTER Switch - PRESS and HOLD.
 - b. PITCH TRIM Circuit Breaker - PULL.
 - c. Aircraft - RETRIM manually.

SECTION 4 - NORMAL PROCEDURES

(a) PREFLIGHT (PERFORM PRIOR TO EACH FLIGHT)

- (1) GYROS - Allow 3-4 minutes for gyros to come up to speed.
- (2) RADIO POWER Switch - ON
- (3) PREFLIGHT TEST BUTTON - PRESS momentarily and NOTE:
 - a. All annunciator lights on (TRIM annunciator flashing).
 - b. After approximately 5 seconds, all annunciator lights off except AP which will flash approximately 12 times and then remain off.

NOTE

If trim warning light stays on then the manual electric trim did not pass preflight test. The pitch trim circuit breaker should be pulled. The autopilot can still be used.

- (4) MANUAL ELECTRIC TRIM (if installed) - TEST as follows:
 - a. Actuate the left side of the split switch to the fore and aft positions. The trim wheel should not move on its own. Rotate the trim wheel manually against the engaged clutch to check the pilot's overpower capability.
 - b. Actuate right side of split switch unit to the fore and aft positions. The trim wheel should not move on its own and normal trim wheel force is required to move it manually.
 - c. Press the AP DISC/TRIM INTER switch down and hold. Manual Electric Trim should not operate either nose up or or nose down.
- (5) AUTOPILOT - ENGAGE by pressing AP ENG button.
- (6) CONTROL WHEEL - MOVE left and right to verify that the autopilot can be overpowered.
- (7) AP DISC/TRIM INTER Switch - PRESS. Verify that the autopilot disconnects and all modes are cancelled.
- (8) TRIM - SET to take off position.

(b) AUTOPILOT OPERATION

- (1) Before takeoff
AP DISC/TRIM INTER Switch - PRESS.

- (2) Autopilot Engagement
AP ENG Button - PRESS. Note AP annunciator on. If no other modes are selected the autopilot will operate in the wings level mode.
- (3) Heading Changes
 - a. Manual Heading Changes
 - 1. CWS Button - PRESS and MANEUVER aircraft to the desired heading.
 - 2. CWS Button - RELEASE. Autopilot will maintain aircraft in wings level attitude.

NOTE

Aircraft heading may change in the wings level mode due to an aircraft out of trim condition.

- b. Heading Hold
 - 1. Heading Selector Knob - SET BUG to desired heading.
 - 2. HDG Mode Selector Button - PRESS. Note HDG mode annunciator ON. Autopilot will automatically turn the aircraft to the selected heading.
 - c. Command Turns (Heading Hold Mode ON)
HEADING Selector Knob - MOVE BUG to the desired heading. Autopilot will automatically turn the aircraft to the new selected heading.
- (4) NAV Coupling
 - a. When equipped with HSI.
 - 1. Course Bearing Pointer - SET to desired course.

NOTE

When equipped with NAV 1/NAV 2 switching and NAV 2 is selected, set OBS to the desired course.

- 2. HEADING SELECTOR KNOB - SET BUG to provide desired intercept angle.

3. NAV Mode Selector Button - PRESS.

If the Course Deviation Bar is greater than 2 to 3 dots: the aircraft will continue in HDG mode (or wings level if HDG not selected) with the NAV annunciator flashing; when the computed capture point is reached the HDG will disengage, the NAV annunciator will illuminate steady and the selected course will be automatically captured and tracked.

If the D-Bar is less than 2 to 3 dots: the HDG mode will disengage upon selecting NAV mode; the NAV annunciator will illuminate steady and the capture/track sequence will automatically begin.

b. When equipped with DG

1. OBS Knob - SELECT desired course.
2. NAV Mode Selector Button - PRESS.
3. Heading Selector Knob - ROTATE BUG to agree with OBS course.

NOTE

When NAV is selected, the lateral operating mode will change from HDG (if selected) to wings level for 5 seconds. A 45° intercept angle will then be automatically established based on the position of the bug.

If the D-Bar is greater than 2 to 3 dots: the autopilot will annunciate HDG mode (unless HDG not selected) and NAV flashing; when the computed capture point is reached the HDG annunciator will go out, the NAV annunciator will illuminate steady and the selected course will be automatically captured and tracked.

If the D-Bar is less than 2 to 3 dots: the HDG mode will disengage upon selecting NAV mode; the NAV annunciator will illuminate steady and the capture/track sequence will automatically begin.

- (5) Approach (APR) Coupling
- a. When equipped with HSI
 1. Course Bearing Pointer - SET to desired course.

NOTE

When equipped with NAV 1/NAV 2 switching and NAV 2 is selected, set OBS to the desired course.

2. HEADING Selector Knob - SET BUG to provide desired intercept angle.
 3. APR Mode Selector Button - PRESS.
If the Course Deviation Bar is greater than 2 to 3 dots: the aircraft will continue in HDG mode (or wings level if HDG not selected) with the APR annunciator flashing; when the computed capture point is reached the HDG will disengage, the APR annunciator will illuminate steady and the selected course will be automatically captured and tracked.

If the D-Bar is less than 2 to 3 dots: the HDG mode will disengage upon selecting APR mode; the APR annunciator will illuminate steady and the capture/track sequence will automatically begin.
- b. When equipped with DG
 1. OBS Knob - SELECT desired approach course.
 2. APR Mode Selector Button - PRESS.
 3. Heading Selector Knob - ROTATE Bug to agree with OBS course.

NOTE

When APR is selected, the lateral operating mode will change from HDG (if selected) to wings level for 5 seconds. A 45° intercept angle will then be automatically established based on the position of the bug.

If the D-Bar is greater than 2 to 3 dots: the autopilot will annunciate HDG mode (unless HDG not selected) and APR flashing; when the computed capture point is reached the HDG annunciator will go out, the APR annunciator will illuminate steady and the selected course will be automatically captured and tracked.

If the D-Bar is less than 2 to 3 dots: the HDG mode will disengage upon selecting APR mode; the APR annunciator will illuminate steady and the capture/track sequence will automatically begin.

- (6) BC Approach Coupling
 - a. When equipped with HSI
 - 1. Course Bearing Pointer - SET to the ILS front course inbound heading.

NOTE

When equipped with NAV 1/NAV 2 switching and NAV 2 is selected, set OBS to the ILS front course inbound heading.

- 2. HEADING Selector Knob - SET BUG to provide desired intercept angle.
- 3. BC Mode Selector Button - PRESS.

If the Course Deviation Bar is greater than 2 to 3 dots: the aircraft will continue in HDG mode (or wings level if HDG not selected) with BC annunciated steady and APR annunciator flashing; when the computed capture point is reached the HDG will disengage, the BC and APR annunciators will illuminate steady and the selected course will be automatically captured and tracked.

If the D-Bar is less than 2 to 3 dots: the HDG mode will disengage upon selecting BC mode; the APR BC annunciator will illuminate steady and the capture/track sequence will automatically begin.

- b. When equipped with DG
 - 1. OBS Knob - SELECT the ILS front course inbound heading.
 - 2. BC Mode Selector Button - PRESS.

3. Heading Selector Knob - ROTATE Bug to the ILS front course inbound heading.

NOTE

When BC is selected, the lateral operating mode will change from HDG (if selected) to wings level for 5 seconds. A 45° intercept angle will then be established based on the position of the bug.

If the D-Bar is greater than 2 to 3 dots: the autopilot will annunciate HDG and BC modes with APR flashing; when the computed capture point is reached the HDG annunciator will go out, the APR annunciator will illuminate steady and the selected course will be automatically captured and tracked.

If the D-Bar is less than 2 to 3 dots: the HDG mode will disengage upon selecting BC mode; the APR BC annunciator will illuminate steady and the capture/track sequence will automatically begin.

- (7) Missed Approach
 - a. AP DISC/TRIM INTER - PRESS to disengage AP.
 - b. MISSED APPROACH - EXECUTE.
 - c. AP ENG Button - PRESS (if AP operation is desired).
Note AP annunciator ON.
- (8) Before Landing
AP DISC/TRIM INTER - PRESS to disengage AP.

SECTION 5 - PERFORMANCE

No change.

SECTION 6 - WEIGHT AND BALANCE

Factory installed optional equipment is included in the licensed weight and balance data in Section 6 of the Basic Pilot's Operating Handbook.

SECTION 7 - DESCRIPTION AND OPERATION

The KAP 100 Autopilot is certified in this airplane with roll axis control. The various instruments and the controls for the operation of the KAP 100 Autopilot are described in Figures 7-1 thru 7-11.

The KAP 100 Autopilot has an optional electric pitch trim system. The trim system is designed to withstand any single inflight malfunction. A trim fault is visually and aurally annunciated.

A lockout device prevents autopilot engagement until the system has been successfully preflight tested.

The following conditions will cause the Autopilot to automatically disengage:

- (a) Power failure.
- (b) Internal Flight Control System failure.
- (c) With the KCS 55A Compass System, a loss of compass valid (displaying HDG flag) disengages the Autopilot when a mode using heading information is engaged. With the HDG flag present only the autopilot wings level mode can be selected.
- (d) Roll rates in excess of 16° per second will cause the autopilot to disengage except when the CWS switch is held depressed.

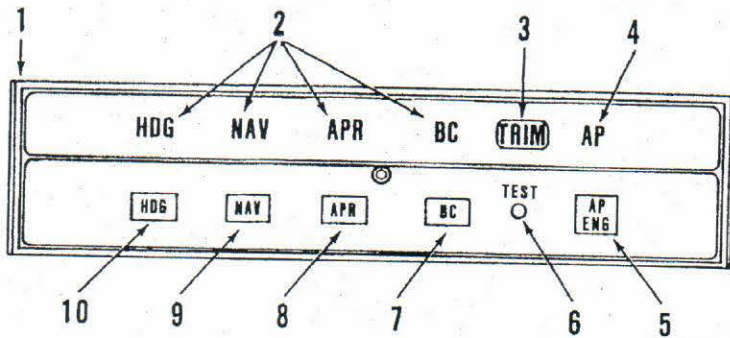

KC 190 AUTOPILOT COMPUTER

Figure 7-1

1. KAP 100 AUTOPILOT COMPUTER - Complete Autopilot computer. Includes system mode annunciators and system controls.
2. MODE ANNUNCIATORS - Illuminate when a mode is selected by the corresponding mode selector button (PUSH ON - PUSH OFF).
3. TRIM WARNING LIGHT (TRIM) - Illuminates continuously whenever trim power is not on or the system has not been pre-flight tested. The TRIM warning light, located on the right side of the computer, will flash and be accompanied by an audible warning whenever a manual pitch trim malfunction occurs (trim running without being commanded to run).
4. AUTOPILOT ANNUNCIATOR (AP) - Illuminates continuously whenever the autopilot is engaged. Flashes approximately 12 times whenever the autopilot is disengaged (an aural alert will also sound for 2 seconds).
5. AUTOPILOT ENGAGE (AP ENG) BUTTON - When pushed, engages autopilot if all logic conditions are met.

Figure 7-1 (cont)

6. **PREFLIGHT TEST (TEST) BUTTON** - When momentarily pushed, initiates preflight test sequence which automatically turns on all annunciator lights, tests the roll rate monitor, checks the manual trim drive voltage, checks the manual electric trim monitor and tests all autopilot valid and dump logic. If the preflight is successfully passed, the AP annunciator light will flash for approximately 6 seconds (an aural tone will also sound simultaneously with the annunciator flashes). The autopilot cannot be engaged until the preflight test is successfully passed.
7. **BACK COURSE APPROACH (BC) MODE SELECTOR BUTTON** - When pushed, will select the Back Course Approach mode. This mode functions identically to the approach mode except that response to LOC signals is reversed.
8. **APPROACH (APR) MODE SELECTOR BUTTON** - When pushed, will select the Approach mode. This mode provides all angle intercept (with HSI) or a fixed angle intercept of 45° (with DG), automatic beam capture and tracking of VOR, RNAV or LOC signals. The tracking gain of the APR mode is greater than the gain in the NAV mode. The APR annunciator will flash until the automatic capture sequence is initiated.
9. **NAVIGATION (NAV) MODE SELECTOR BUTTON** - When pushed, will select the Navigation mode. The mode provides all angle intercept (with HSI) or a fixed angle intercept of 45° (with DG), automatic beam capture and tracking of VOR, RNAV or LOC signals. The NAV annunciator will flash until the automatic capture sequence is initiated.
10. **HEADING (HDG) MODE SELECTOR BUTTON** - When pushed, will select the Heading mode, which commands the airplane to turn to and maintain the heading selected by the heading bug on the DG or HSI. A new heading may be selected at any time and will result in the airplane turning to the new heading with a maximum bank angle of about 20°. Selecting HDG mode will cancel NAV, APR or BC track modes.

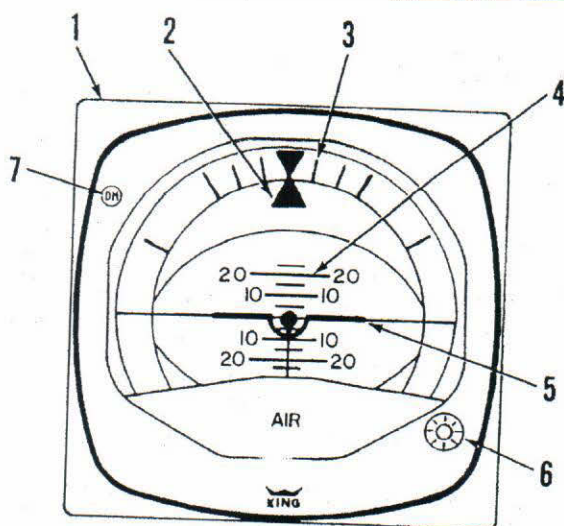

KG 258 VERTICAL GYRO

Figure 7-3

1. KG 258 VERTICAL GYRO - Displays airplane attitude as a conventional attitude gyro. The gyro is air driven.
2. ROLL ATTITUDE INDEX - Displays airplane roll attitude with respect to the roll attitude scale.
3. ROLL ATTITUDE SCALE - Scale marked at 0, +/- 10, +/- 20, +/- 30, +/- 60 and +/- 90 degrees.
4. PITCH ATTITUDE SCALE - Moves with respect to the symbolic airplane to present pitch attitude. Scale graduated at 0, +/- 5, +/- 10, +/- 15, +/- 20 and +/- 25 degrees.
5. SYMBOLIC AIRPLANE - Serves as a stationary symbol of the aircraft. Aircraft pitch and roll attitudes are displayed by the relationship between the fixed symbolic aircraft and the movable background.
6. SYMBOLIC AIRCRAFT ALIGNMENT KNOB - Provides manual positioning of the symbolic aircraft for level flight under various load conditions.
7. DECISION HEIGHT (DH) ANNUNCIATOR LIGHT - Optional light for use with the aircraft's optional radar altimeter.

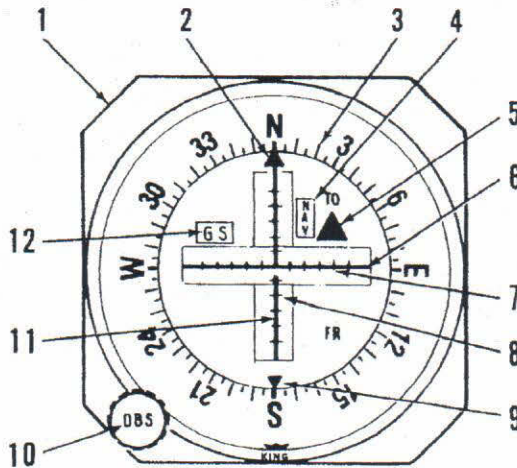

KI 204/206 VOR/LOC/
GLIDE SLOPE INDICATOR (TYPICAL)

Figure 7-5

1. VOR/LOC/GLIDE SLOPE INDICATOR - Provides rectilinear display of VOR/LOC and Glide slope deviation.
2. COURSE INDEX - Indicates selected VOR course.
3. COURSE CARD - Indicates selected VOR course under course index.
4. NAV FLAG - Flag is in view when the NAV receiver signal is inadequate. When a NAV flag is present in the navigation indicator (CDI or KI 525A) the autopilot operation is not affected. The pilot must monitor the navigation indicators for NAV flags to insure that the Autopilot is tracking valid navigation information.
5. TO/FROM INDICATOR FLAG - Indicates direction of VOR station relative to selected course.
6. GLIDE SLOPE DEVIATION NEEDLE - Indicates deviation from ILS glide slope.
7. COURSE DEVIATION SCALE - A course deviation bar displacement of 5 dots represents full scale (VOR = $\pm 10^\circ$, LOC = $\pm 2\ 1/2^\circ$, RNAV = 5NM, RNAV APR - 1 1/4NM) deviation from beam centerline.

Figure 7-5 (cont)

8. GLIDE SLOPE SCALE - Indicates displacement from glide slope beam center. A glide slope deviation needle displacement of 5 dots, represents full scale (0.7°) deviation above or below glide slope beam centerline.
9. RECIPROCAL COURSE INDEX - Indicates reciprocal of selected VOR course.
10. OMNI BEARING SELECTOR (OBS) KNOB - Rotates course card to selected course.
11. COURSE DEVIATION NEEDLE - Indicates course deviation from selected omni course or localizer centerline.
12. GLIDE SLOPE (GS) FLAG - Flag is in view when the GS receiver signal is inadequate.

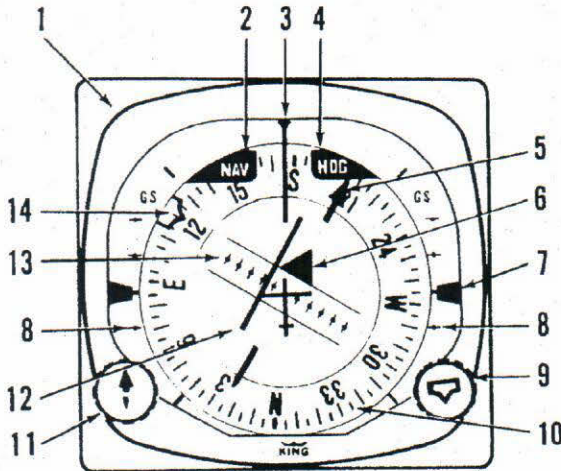

KI 525A HORIZONTAL SITUATION INDICATOR

Figure 7-7

Figure 7-7 (cont)

1. KI 525A HORIZONTAL SITUATION INDICATOR (HSI) - Provides a pictorial presentation of aircraft deviation relative to VOR radials or localizer beams. It also displays glide slope deviations and gives heading reference with respect to magnetic north.
2. NAV FLAG - Flag is in view when the NAV receiver signal is inadequate. When a NAV flag is present in the navigation indicator (CDI or KI 525A) the autopilot operation is not affected. The pilot must monitor the navigation indicators for NAV flags to insure that the Autopilot is tracking valid navigation information.
3. LUBBER LINE - Indicates aircraft magnetic heading on compass card (10).
4. HEADING WARNING FLAG (HDG) - When flag is in view the heading display is invalid. If a HDG flag appears and a lateral mode (HDG, NAV, APR or APR BC) is selected, the Autopilot will be disengaged. The Autopilot may be re-engaged in the basic wings level mode. The CWS switch would be used to maneuver the aircraft laterally.
5. COURSE BEARING POINTER - Indicates selected VOR course or localizer course on compass card (10). The selected VOR radial or localizer heading remains set on the compass card when the compass card (10) rotates.
6. TO/FROM INDICATOR FLAG - Indicates direction of VOR station relative to selected course.
7. DUAL GLIDE SLOPE POINTERS - Indicate on glide slope scale (8) aircraft displacement from glide slope beam center. Glide slope pointers in view indicate a usable glide slope signal is being received.
8. GLIDE SLOPE SCALES - Indicate displacement from glide slope beam center. A glide slope deviation bar displacement of 2 dots represents full scale (0.7°) deviation above or below glide slope beam centerline.
9. HEADING SELECTOR KNOB () - Positions heading Bug (14) on compass card (10) by rotating the heading selector knob. The Bug rotates with the compass card.
10. COMPASS CARD - Rotates to display heading of airplane with reference to lubber line (3) on HSI.
11. COURSE SELECTOR KNOB - Positions course bearing pointer (5) on the compass card (10) by rotating the course selector knob.
12. COURSE DEVIATION BAR (D-BAR) - The center portion of omni bearing pointer moves laterally to pictorially indicate the relationship of aircraft to selected course. It indicates in degrees of angular displacement from VOR radials and localizer beams or displacement in nautical miles from RNAV courses.

Figure 7-7 (cont)



13. COURSE DEVIATION SCALE - A course deviation bar displacement of 5 dots represents full scale (VOR = +/- 10°, LOC = +/- 2 1/2°, RNAV = 5NM, RNAV APR - 1 1/4NM) deviation from beam centerline.
14. HEADING BUG - Moved by () knob (9) to select desired heading.

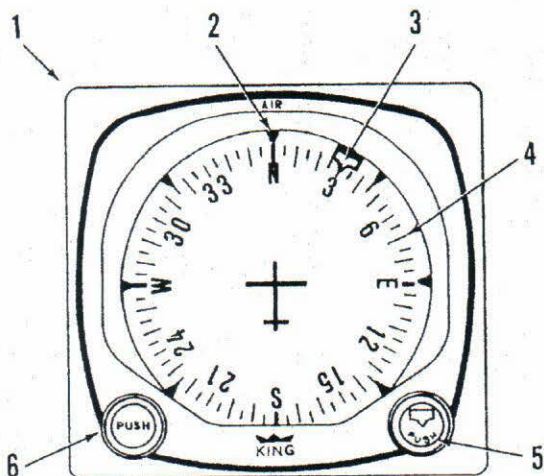

KG 107 NON-SLAVED DIRECTIONAL GYRO

Figure 7-9

Figure 7-9 (cont)

1. KG 107 NON-SLAVED DIRECTIONAL GYRO (DG) - Provides a stable visual indication of aircraft heading to the pilot. The gyro is air driven.
2. LUBBER LINE - Indicates aircraft magnetic heading on compass card(4).
3. HEADING BUG - Moved by () knob (5) to select desired heading.
4. COMPASS CARD - Rotates to display heading of airplane with reference to lubber line (2) on DG.
5. HEADING SELECTOR KNOB () - Positions heading Bug (3) on compass card (4) by rotating the heading selector knob The Bug rotates with the compass card.
6. GYRO ADJUSTMENT KNOB (PUSH) - When pushed in, allows the pilot to manually rotate the gyro compass card (4) to correspond with the magnetic heading indicated by the magnetic compass. The unslaved compass card must be manually reset periodically to compensate for precessional errors in the gyro.

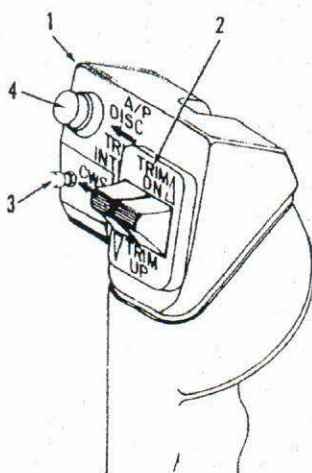

AUTOPILOT CONTROL WHEEL SWITCH CAP

Figure 7-11

1. **AUTOPILOT CONTROL WHEEL SWITCH CAP** - Molded plastic unit mounted on the left horn of the pilot's control wheel which provides mounting for three switch units associated with the autopilot and manual electric trim systems (only used with optional manual electric trim).
2. **MANUAL ELECTRIC TRIM CONTROL SWITCHES** - A split switch unit in which the left half provides power to engage the trim servo clutch and the right half to control the direction of motion of the trim servo motor. Both halves of the split trim switch must be actuated in order for the manual trim to operate in the desired direction.
3. **CONTROL WHEEL STEERING (CWS) BUTTON** - When depressed, allows pilot to manually control the aircraft (disengages the servo) without cancellation of any of the selected modes.
4. **AUTOPILOT DISCONNECT/TRIM INTERRUPT (AP DISC/TRIM INTER) Switch** - When depressed and released, will disengage the autopilot and cancel all operating autopilot modes. When depressed and held, will interrupt all electric trim power (stop trim motion), disengage the autopilot, and cancel all operating autopilot modes.

The airplane MASTER SWITCH function is unchanged and can be used in an emergency to shut off electrical power to all flight control systems while the problem is isolated.

The RADIO POWER switch supplies power to the avionics bus bar of the radio circuit breakers and the autopilot circuit breaker.

The following circuit breakers are used to protect the following elements of the King KAP 100 Autopilot:

AUTOPILOT - Supplies power to the KC 190, the autopilot roll servo, and the Pitch Trim Circuit Breaker.

PITCH TRIM - Supplies power to the optional manual electric pitch trim system.

COMP-SYSTEM - Supplies power to the optional KCS 55A Compass System.

THIS PAGE INTENTIONALLY LEFT BLANK

PILOT'S OPERATING HANDBOOK
AND
FAA APPROVED AIRPLANE FLIGHT MANUAL

SUPPLEMENT NO. 4
FOR
AUXILIARY VACUUM SYSTEM

This supplement must be attached to the Pilot's Operating Handbook and FAA Approved Airplane Flight Manual when the Piper Auxiliary Vacuum System is installed in accordance with Piper Drawing No. 87773-2. The information contained herein supplements or supersedes the basic Pilot's Operating Handbook and FAA Approved Airplane Flight Manual only in those areas listed herein. For limitations, procedures and performance information not contained in this supplement, consult the basic Pilot's Operating Handbook and FAA Approved Airplane Flight Manual.

FAA APPROVED

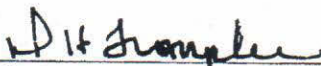

D. H. TROMPLER
D.O.A. NO. SO-1
PIPER AIRCRAFT CORPORATION
VERO BEACH, FLORIDA

DATE OF APPROVAL October 7, 1988

ISSUED: SEPTEMBER 9, 1988

REPORT: VB-1360
1 of 6, 9-31

SECTION 1 - GENERAL

This supplement supplies information necessary for the operation of the airplane when the optional Piper Auxiliary Vacuum System is installed. The information contained within this supplement is to be used in conjunction with the complete handbook.

SECTION 2 - LIMITATIONS

- (a) The auxiliary vacuum system is limited to standby function only, do not take off with the engine driven dry air pump inoperative.
- (b) Discontinue flight in Instrument Meteorological Conditions (IMC) if vacuum pressure falls below 4.8 in. Hg.
- (c) The auxiliary pump/motor assembly and elapsed time indicator must be removed from service after 500 hours accumulated operating time or 10 years, whichever occurs first.

SECTION 3 - EMERGENCY PROCEDURES

LOSS OF VACUUM SUCTION

- (a) Low VAC warning and VAC OFF lights illuminated:
Vacuum suction gauge..... check to verify inop pump
- (b) If vacuum suction gauge below 4.5 inches Hg:
Auxiliary vacuum switch..... push AUX ON

Verify vacuum suction 4.8 to 5.2 inches Hg. and Vac and VAC OFF annunciator lights out and AUX ON light illuminated.

CAUTION

Compass error may exceed 10° when auxiliary vacuum system is in operation.

- (c) Monitor electrical load - verify alternator capacity is not being exceeded as indicated by the ammeter. If required turn off non-essential electrical equipment.
- (d) Land at the earliest opportunity to have primary system repaired.

SECTION 4 - NORMAL PROCEDURES

(a) Preflight Check.

1. Turn on battery switch and verify VAC OFF light illuminated.

NOTE

Due to the electrical power requirement of the auxiliary vacuum pump it is suggested that the engine be operating while making the following checks.

2. Turn on auxiliary vacuum pump and verify AUX ON light is illuminated and electrical load (approximate 15 amps) on ammeter.
3. Turn off auxiliary vacuum pump and verify AUX ON light extinguished.

(b) Inflight Check. — Prior to entering instrument flight conditions:

1. Turn off nonessential electrical equipment.
2. Turn on auxiliary vacuum pump and verify AUX ON light illuminated and electrical load (approximately 15 amps on ammeter).
3. Turn off auxiliary vacuum pump and verify AUX ON light extinguished and return to normal flight.

NOTE

For maximum service life, avoid continuous non-emergency operation of the auxiliary vacuum pump.

SECTION 5 - PERFORMANCE

No change.

SECTION 6 - WEIGHT & BALANCE

Factory installed optional equipment is included in the licensed weight and balance data in Section 6 of the Basic Pilot's Operating Handbook.

SECTION 7 - DESCRIPTION AND OPERATION

The auxiliary dry air pump system provides an independent back-up source of pneumatic power to operate the gyro flight instruments in the event the engine driven air pump fails.

The auxiliary pump is mounted on the forward side of the firewall and connects to the primary system at a manifold downstream of the vacuum regulator. Isolation of the primary and auxiliary systems from each other is accomplished by check valves on each side of the manifold. The primary system vacuum switch is located on the regulator and senses vacuum supplied to the gyros.

A control switch (labeled AUX VAC) for the auxiliary pump system is located on the right side of the instrument panel near the vacuum suction gauge. The control switch operating modes are "push-for-on" and "push-for-off".

The switch button incorporates two annunciator light sections labeled VAC OFF and AUX ON. The VAC OFF section is controlled by a vacuum switch in the primary pneumatic system and illuminates an amber light when the engine driven pump is inoperative or when the system vacuum falls below the switch activation level. The AUX ON section is controlled by a vacuum switch on the manifold and illuminates a blue light when the auxiliary pump is operating and creating a vacuum in the system. When the auxiliary pump is activated at high altitude, or if the system has developed air leaks, the AUX ON light may fail to illuminate. This indicates that the system vacuum is still below the AUX ON switch activation level even though the auxiliary pump is operating. The annunciator lights do not incorporate a press-to-test feature; if the lights do not illuminate, check for burned out lamps. Replace, as necessary, with MS25237-330 bulbs and retest the system.

System electrical protection is provided by a 20 amp circuit breaker in the pump motor circuit and a 5 amp circuit breaker in the annunciator light circuit. The breakers are mounted on the circuit breaker panel.

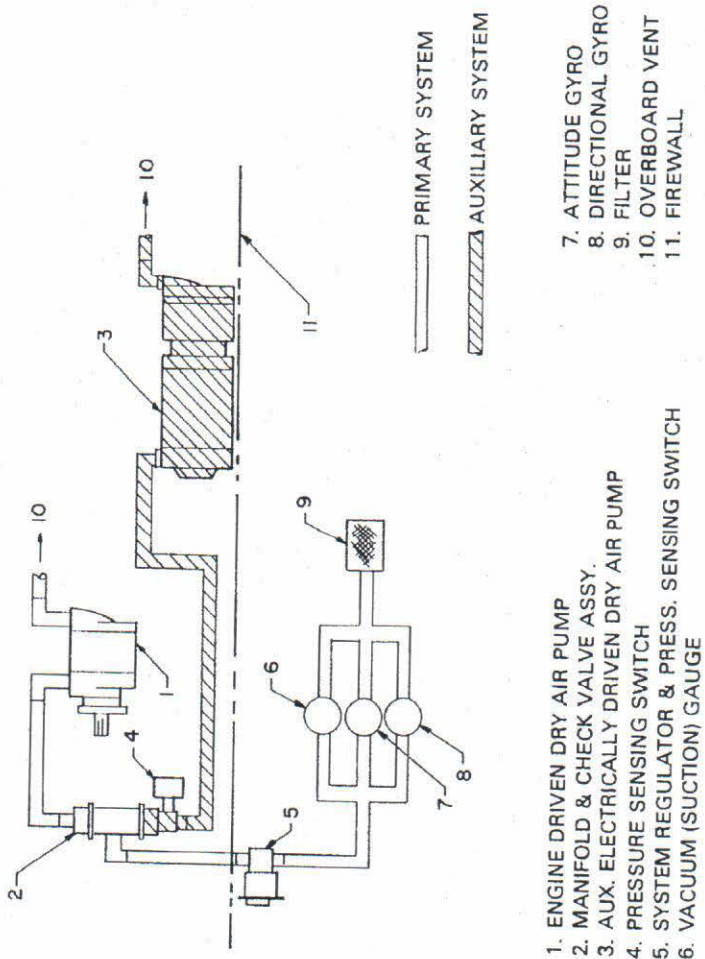

VACUUM SYSTEM SCHEMATIC

Figure 7-1

ISSUED: SEPTEMBER 9, 1988

REPORT: VB-1360
5 of 6, 9-35

THIS PAGE INTENTIONALLY LEFT BLANK

TABLE OF CONTENTS

SECTION 10

OPERATING TIPS

Paragraph No.		No.
10.1	General	10-1
10.3	Operating Tips	10-1

SECTION 10
OPERATING TIPS

10.1 GENERAL

This section provides operating tips of particular value in the operation of the Cadet.

10.3 OPERATING TIPS

- (a) Learn to trim for takeoff so that only a very light back pressure on the control wheel is required to lift the airplane off the ground.
- (b) The best speed for takeoff is about 55 KIAS under normal conditions. Trying to pull the airplane off the ground at too low an airspeed decreases the controllability of the airplane in the event of engine failure.
- (c) Flaps may be lowered at airspeeds up to 103 KIAS. To reduce flap operating loads, it is desirable to have the airplane at a slower speed before extending the flaps. The flap step will not support weight if the flaps are in any extended position. The flaps must be placed in the UP position before they will lock and support weight on the step.
- (d) Before attempting to reset any circuit breaker, allow a two to five minute cooling off period.
- (e) Before starting the engine, check that all radio switches, light switches and the pitot heat switch are in the off position so as not to create an overloaded condition when the starter is engaged.
- (f) Anti-collision lights should not be operating when flying through cloud, fog or haze, since the reflected light can produce spatial disorientation. Strobe lights should not be used in close proximity to the ground such as during taxiing, takeoff or landing.

- (g) The rudder pedals are suspended from a torque tube which extends across the fuselage. The pilot should become familiar with the proper positioning of his feet on the rudder pedals so as to avoid interference with the torque tube when moving the rudder pedals or operating the toe brakes.
- (h) In an effort to avoid accidents, pilots should obtain and study the safety related information made available in FAA publications such as regulations, advisory circulars, Aviation News, AIM and safety aids.
- (i) Prolonged slips or skids which result in excess of 2000 ft. of altitude loss, or other radical or extreme maneuvers which could cause uncovering of the fuel outlet must be avoided as fuel flow interruption may occur when tank being used is not full.
- (j) Hand starting of the engine is not recommended, however, should hand starting of the engine be required, only experienced personnel should attempt this procedure. The magneto selector should be placed to LEFT during the starting procedures to reduce the probability of kick back. Place the ignition switch to BOTH position after the engine has started.